

STANDARD TOLERANCES (UNLESS OTHERWISE NOTED)			
	DECIMAL (IN)	FRACTIONS (IN)	ANGLES (DEG)
MACHINE	.XX ±.01	.XXX ±.005	+ 1/64 - 1/2
FABRICATION			+ 1/16 - 1
CASTING/FORGING	+ - 0.031	+ - 1/32	+ - 1/2

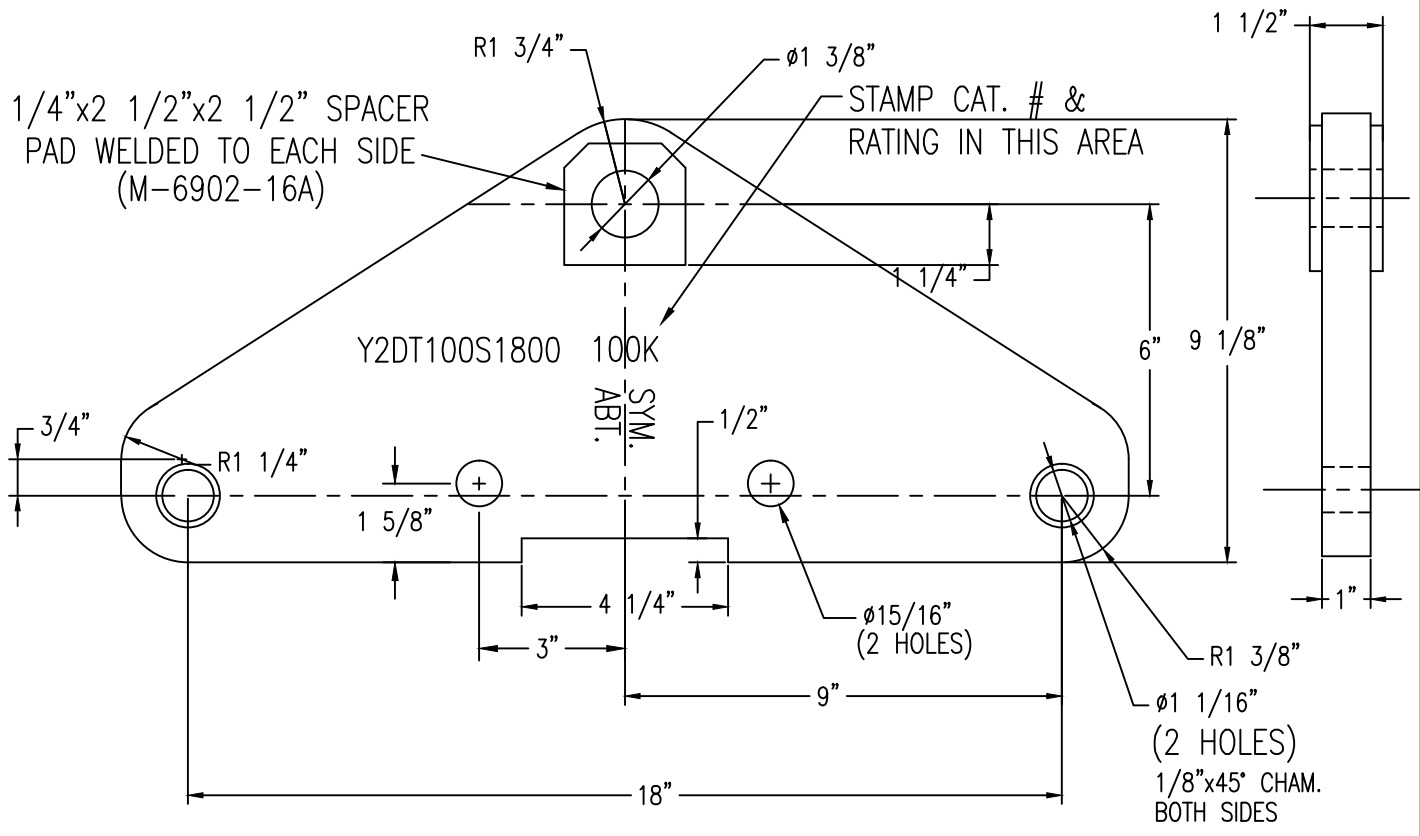

NOTES:

1. MATERIAL - STEEL, ASTM A572 GR. 50
HOT DIP GALVANIZED PER ASTM A153
2. ULTIMATE STRENGTH - 100,000 LBS.
3. MARKING- Y2DT100S1800, 100K (3/8" LETTERS)
4. REMOVE ALL BURRS AND RAGGED EDGES
5. ALL HOLES TO BE DRILLED
6. TO BE FLAME CUT, NO SHEARING
7. EST. WEIGHT 40 LBS

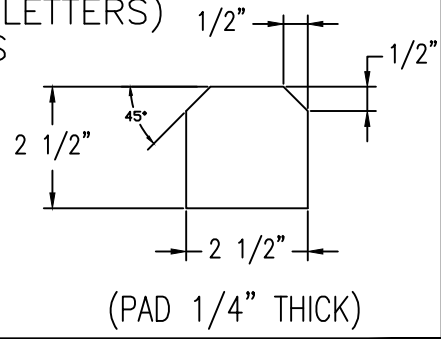

NO.	DATE	DESCRIPTION	BY	CKD
2	7/13/11	Pad was 3/8" thick	BS	
1	8/11/10	Added marking 100K.	WCL	
REVISIONS				

BETHEA POWER PRODUCTS
PELHAM, ALABAMA A MacLean Power Systems Co.

TRIANGULAR DE STEEL YOKE
 CAT. NO. Y2DT100S1800

DATE: 4/27/10	SCALE: NONE	NO. AM-7360-67	R/2	SH.1 OF 1
DWN: WCL	BY:	BY:		