

REVISIONS				
NO.	DATE	DESCRIPTION	BY	CKD

ITEM NO.	PART NO.	CAT. NO.	DESCRIPTION	QUANTITY			
				A	B	C	D
1	P56109	H-0360-01	COTTER PIN HMP 5/8"	1			
2	P56138	H-0400-04-W	1/2"-13 HEX NUT FIN	4			
3	P56399	H-0520-04	1/2" LOCKWASHER	4			
4	P61165	H-0315-04	5/8" x 2-9/16" CLEVIS PIN	1			
5	P61302	H-0201-41	1/2" U-BOLT	2			
6	P61330	H-0476-06	0.75" x 3.55" CMP. SPRING	1			
7	P81271	*HDSO-130-B	HDSO-130 BODY	1			
8	P81272	*HDSO-130-K	HDSO-130 KEEPER	1			

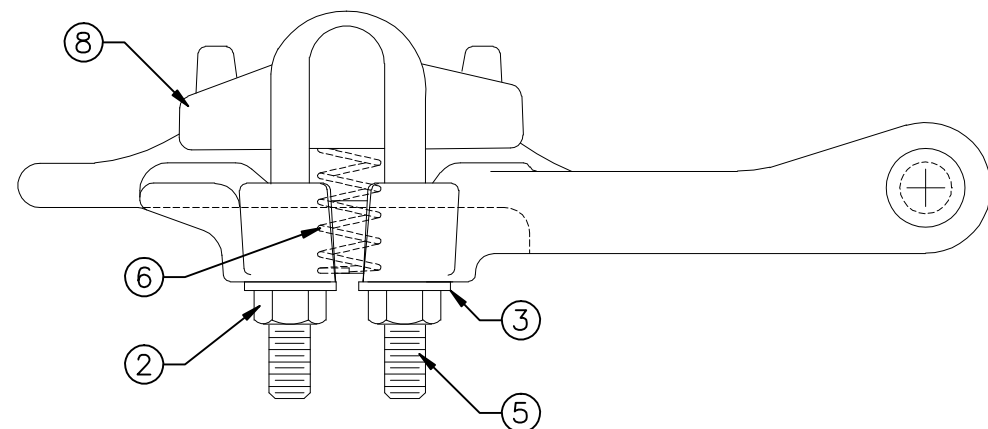
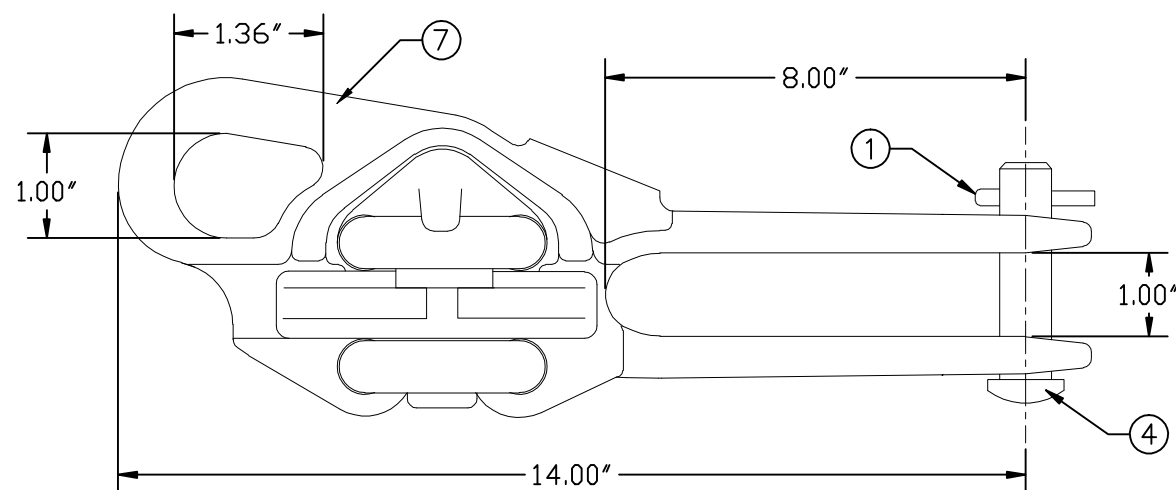

ASSEMBLY NUMBER	REF. NO.
HDSO-130-N	A
	B
	C
	D

NOTES:

- MATERIAL - BODY AND KEEPER:
A356-T6 ALUMINUM ALLOY

HARDWARE:
STEEL, HOT DIP GALVANIZED PER
ASTM-A153

COTTER PIN AND COMP. SPRING:
STAINLESS STEEL
- ULTIMATE STRENGTH - BODY: 15,000 LBS.
EYE: 12,000 LBS.
- CLAMPING RANGE - 0.68" TO 1.30"

 MACLEAN POWER SYSTEMS A Maclean-fogg Company	
HOT LINE DEAD END CLAMP HDSO-130-N	
DATE: 12/08/2011	SCALE: NONE
DWN. BY: CDR	APR. BY:
CKD. BY:	
NO. BC8523-1	R / 0 SH. 1 OF 1

This information is confidential and is the property of Maclean Power Systems. It may not be made public or reproduced except that the Customer may make copies for use solely in installation, maintenance, and operation of products supplied by Maclean Power Systems.

ENG. REF.