

| REVISIONS | | | | |
|-----------|----------|-------------------------------------|-----|-----|
| NO. | DATE | DESCRIPTION | BY | CKD |
| 1 | 03/07/17 | clamping range min used to be 0.19" | MBG | |

| ITEM NO. | PART NO. | CAT. NO. | DESCRIPTION | QUANTITY | | | |
|----------|----------|--------------|----------------------------|----------|---|---|---|
| | | | | A | B | C | D |
| 1 | P55991 | H-0200-04 | 3/8" U-BOLT | 2 | 2 | | |
| 2 | P56094 | H-0315-03 | 5/8" x 2-1/16" CLEVIS PIN | 1 | 1 | | |
| 3 | P56136 | H-0400-03-W | 3/8"-16 HEX NUT FIN | 4 | 4 | | |
| 4 | P56292 | H-0500-03 | 3/8" FLAT-WASHER | 4 | 4 | | |
| 5 | P61134 | M-111-3 | LONG COTTER PIN | 1 | 1 | | |
| 6 | P61136 | H-0476-02 | 0.312" I.D. x 1.88" SPRING | 1 | 1 | | |
| 7 | P64615C | >HDSO-47FB-C | HDSO-47F BODY | 1 | 1 | | |
| 8 | P64616 | >HDSO-47FK | HDSO-47F KEEPER | 1 | 1 | | |
| 9 | P60804 | H-0520-03 | 3/8" LOCKWASHER | - | 4 | | |

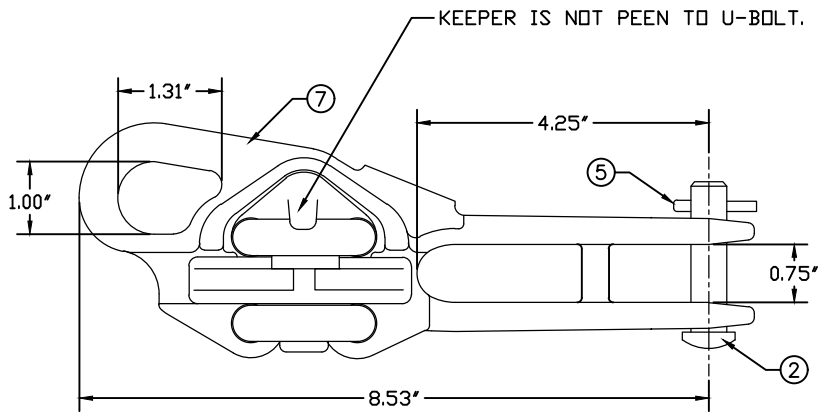

| ASSEMBLY NUMBER | REF. NO. |
|-----------------|----------|
| HDSO-47F | A |
| HDSO-47F-LW | B |
| - - - - - | C |
| - - - - - | D |

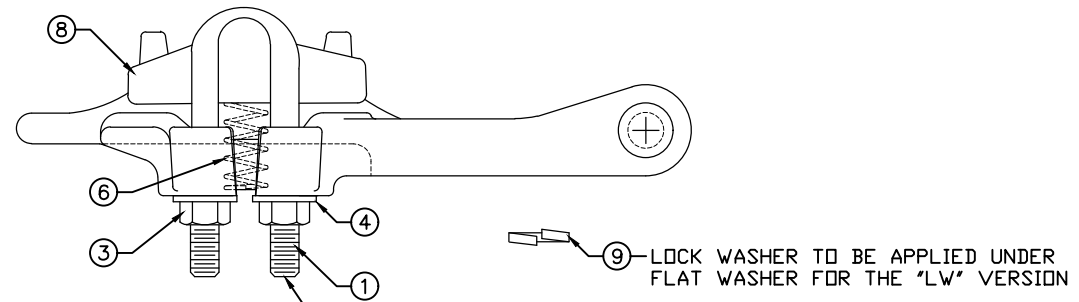

AFTER ASSEMBLED, UPSET THREADS AT BOTH ENDS OF U-BOLTS, BACK OFF THE NUTS AND KEEPS THE KEEPER AT OPEN POSITION.

- NOTES:
- MATERIAL - BODY AND KEEPER:
DUCTILE IRON, HOT DIP GALVANIZED PER ASTM A153.

HARDWARE:
STEEL, HOT DIP GALVANIZED.

COTTER PIN AND COMP. SPRING:
STAINLESS STEEL
 - ULTIMATE STRENGTH - BODY: 8,000 LBS.
EYE: 5,000 LBS.
 - CLAMPING RANGE - 0.16" TO 0.47"
 - RECOMENDED TORQUE - 20-25 FT. LBS.

MACLEAN POWER SYSTEMS
A Maclean-fogg Company

HOT LINE DEAD END CLAMP
HDSO-47F, HDSO-47F-LW

ENG. REF.

This information is confidential and is the property of Maclean Power Systems. It may not be made public or reproduced except that the Customer may make copies for use solely in installation, maintenance, and operation of products supplied by Maclean Power Systems.

| | | | | |
|------------------|-------------|----------|----------|-------|
| DATE: 12/08/2011 | SCALE: NONE | NO. | R / 1 | SHL 1 |
| CHK. BY: CDR | CHK. BY: | APR. BY: | BC8525-1 | OF 1 |