

REVISIONS				
NO.	DATE	DESCRIPTION	BY	CKD

ITEM NO.	PART NO.	CAT. NO.	DESCRIPTION	QUANTITY			
				A	B	C	D
1	P55991	H-0200-04	3/8" U-BOLT	2	2		
2	P56094	H-0315-03	5/8" x 2-1/16" CLEVIS PIN	1	1		
3	P56136	H-0400-03-W	3/8"-16 HEX NUT FIN	4	4		
4	P56292	H-0500-03	3/8" FLAT-WASHER	4	4		
5	P61134	M-111-3	LONG COTTER PIN	1	1		
6	P61136	H-0476-02	0.312" I.D. x 1.88" SPRING	1	1		
7	P64617	>HDSO-57FB	HDSO-57F BODY	1	1		
8	P64618	>HDSO-57FK	HDSO-57F KEEPER	1	1		
9	P60804	H-0520-03	3/8" LOCKWASHER	-	4		

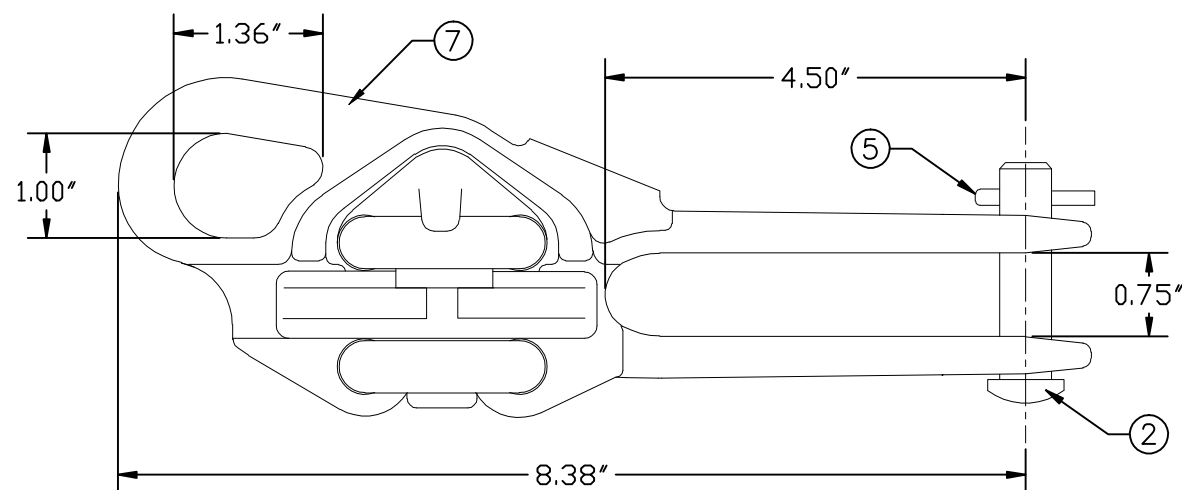

ASSEMBLY NUMBER	REF. NO.
HDSO-57F	A
HDSO-57F-LW	B
- - - - -	C
- - - - -	D

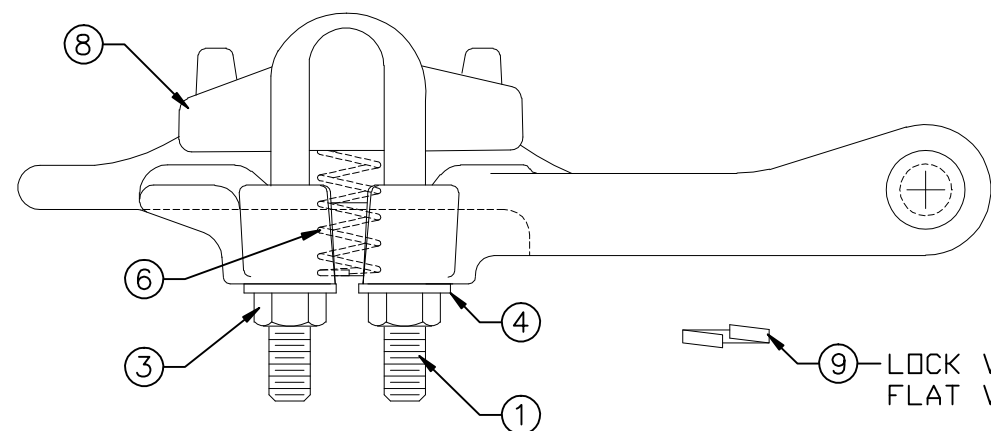

⑨ LOCK WASHER TO BE APPLIED UNDER FLAT WASHER FOR THE "LW" VERSION

NOTES:

1. MATERIAL - BODY AND KEEPER:
DUCTILE IRON

HARDWARE:
STEEL, HOT DIP GALVANIZED PER
ASTM-A153

COTTER PIN AND COMP. SPRING:
STAINLESS STEEL

2. ULTIMATE STRENGTH - BODY: 9,000 LBS.
EYE: 6,000 LBS.

3. CLAMPING RANGE - 0.25" TO 0.57"



MACLEAN POWER SYSTEMS
A Maclean-fogg Company

HOT LINE DEAD END CLAMP
HDSO-57F, HDSO-57F-LW

This information is confidential and is the property of Maclean Power Systems. It may not be made public or reproduced except that the Customer may make copies for use solely in installation, maintenance, and operation of products supplied by Maclean Power Systems.

DATE: 12/08/2011	SCALE: NONE	NO. BC8527-1	R / 0	SH. 1 / OF 1
DWN. BY: CDR	CKD. BY:	APR. BY:		

ENG. REF.