

REVISIONS				
NO.	DATE	DESCRIPTION	BY	CKD

HEX PIN REPLACES CLEVIS  
PIN ON HDSO-88L6HPSCE

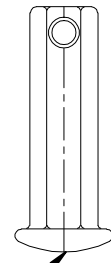

⑨

ITEM NO.	PART NO.	CAT. NO.	DESCRIPTION	QUANTITY			
				A	B	C	D
1	P56138	H-0400-04-W	1/2"-13 HEX NUT FIN	4	4		
2	P56230	H-0470-06	0.5" x 2.75" SPRING	1	1		
3	P56294	H-0500-04	1/2" FLATWASHER	4	4		
4	P61134	M-111-3	LONG COTTER PIN	1	1		
5	P61165	H-0315-04	5/8" x 2-9/16" CLEVIS PIN	1	-		
6	P62159	*HDSO-88-K	HDSO-88 KEEPER	1	1		
7	P62160	*HDSO-88L6-B	HDSO-88L BODY	1	1		
8	P62681	H-0201-32	1/2" STEEL U-BOLT	2	-		
9	P61655	H-0320-04	5/8"φ x 2-9/16" HEX CLEVIS PIN	-	1		
10	P62681W	H-0201-32W	1/2" STEEL U-BOLT (WAXED)	-	2		

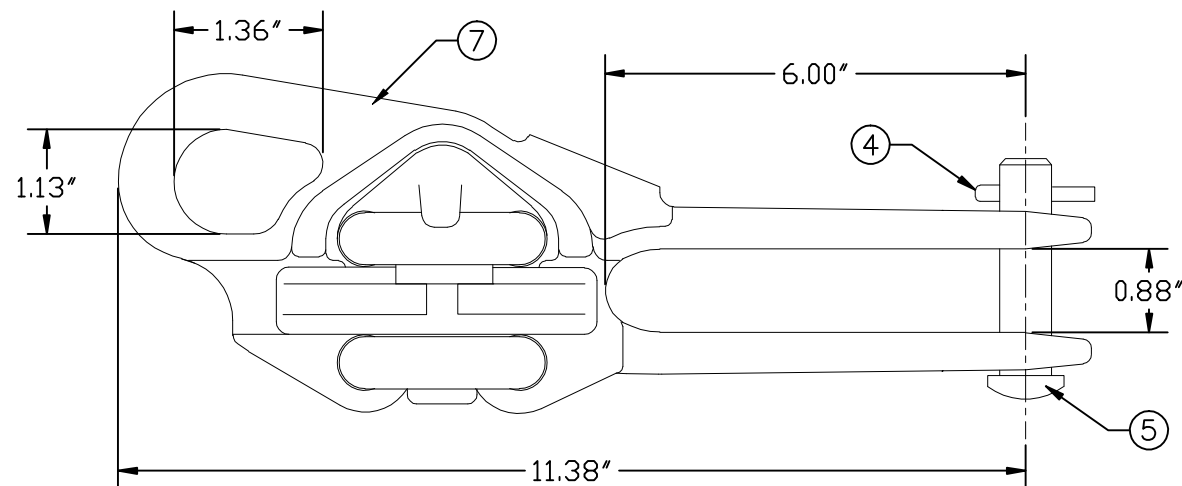

ASSEMBLY NUMBER	REF. NO.
HDSO-88L6	A
HDSO-88L6HPSCE	B
- - - - -	C
- - - - -	D

NOTES:

- MATERIAL - BODY AND KEEPER:  
A356-T6 ALUMINUM ALLOY  
  
HARDWARE:  
STEEL, HOT DIP GALVANIZED PER  
ASTM-A153  
  
COTTER PIN AND COMP. SPRING:  
STAINLESS STEEL
- ULTIMATE STRENGTH - BODY: 10,000 LBS.  
EYE: 6,000 LBS.
- CLAMPING RANGE - 0.25" TO 0.88"

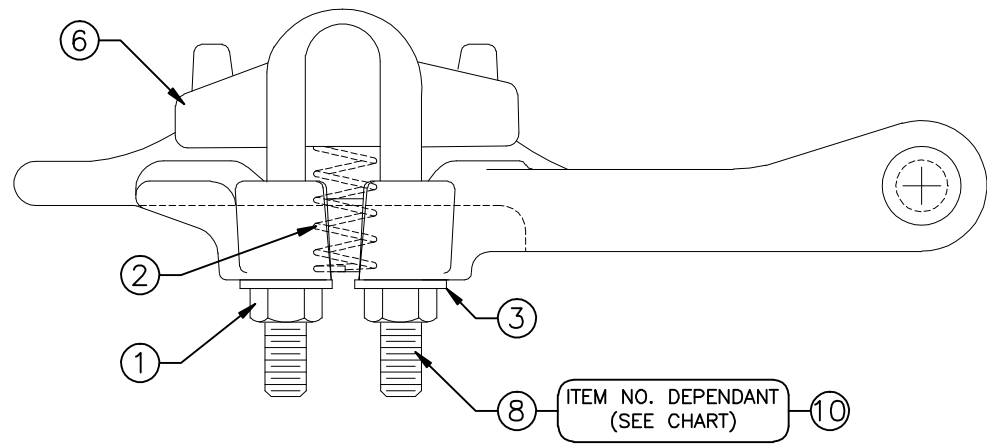

This information is confidential and is the property of Maclean Power Systems. It may not be made public or reproduced except that the Customer may make copies for use solely in installation, maintenance, and operation of products supplied by Maclean Power Systems.

**MACLEAN POWER SYSTEMS**  
A Maclean-fogg Company

HOT LINE DEAD END CLAMP  
HDSO-88L6, HDSO-88L6HPSCE

ENG. REF.

DATE: 12/08/2011	SCALE: NONE	NO. BC8532-1	R / 0	SH. 1 / OF 1
DWN. BY: CDR	CKD. BY:	APR. BY:		