

This information is confidential and is the property of Maclean Power Systems. It may not be made public or reproduced except that the Customer may make copies for use solely in installation, maintenance, and operation of products supplied by Maclean Power Systems.

NO. BC8674-2

ITEM NO.	PART NO.	CAT. NO.	DESCRIPTION	QTY
1	P56073	H-0301-02	CL PIN 3/4"	1
2	P56110	H-0360-02	COTTER PN HMP 3/4"	1
3	P57288	M-0664-01-L	CEA-68-1125L GALV	1

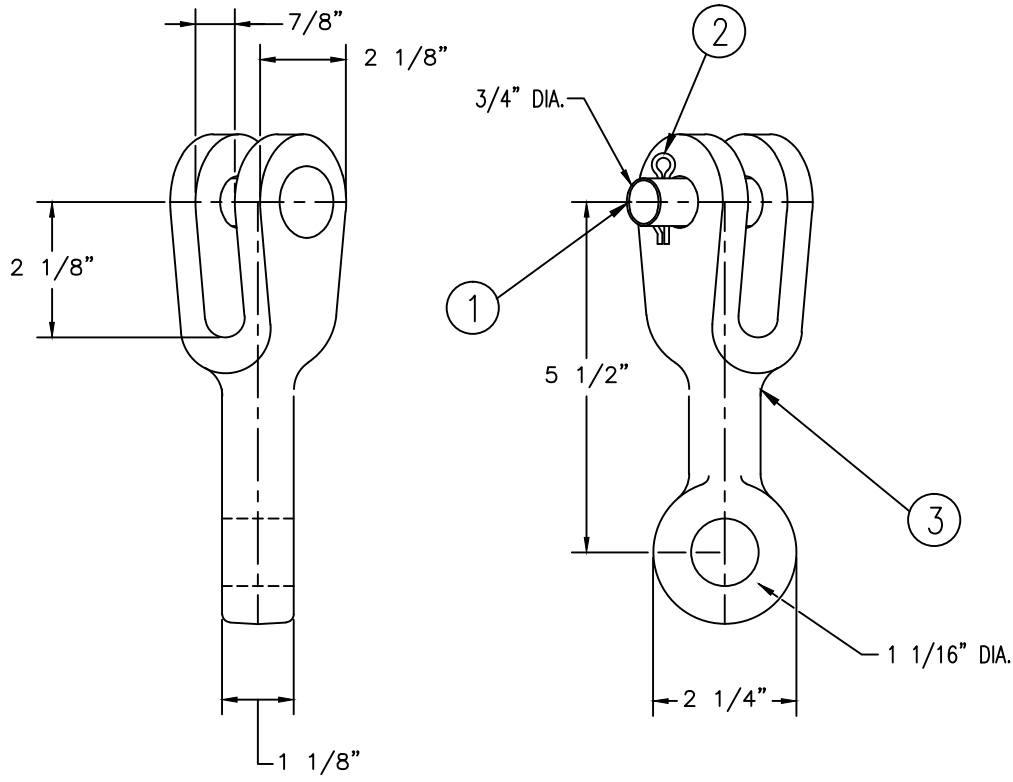

- NOTES:
1. MATERIAL:
 - A. BODY - DUCTILE IRON
 - B. COTTER PIN - AISI 302 STAINLESS STEEL
 - C. HARDWARE - STEEL, HOT DIP GALVANIZED
 2. FINISH: HOT DIP GALVANIZED PER ASTM A153
 3. ULTIMATE STRENGTH: 45,000 LBS.
 4. WEIGHT: 3.630 LBS.

NO.	DATE	DESCRIPTION	BY	CKD
REVISIONS				

MACLEAN POWER SYSTEMS
A Maclean-fogg Company

CEA CLEVIS EYE 45 DEG
CATALOG NO: CEA 68-1125L

DATE: 4/10/17	SCALE: NONE	NO. BC8674-2	R/0
BY: BS	BY:	BY:	SH.1 OF 1