

This information is confidential and is the property of Maclean Power Systems. It may not be made public or reproduced except that the Customer may make copies for use solely in installation, maintenance, and operation of products supplied by Maclean Power Systems.

NO. BC-8742-1

ITEM NO.	PART NO.	CAT. NO.	DESCRIPTION	QTY
1	P55834	H-0100-02	7/8" BENT BOLT	1
2	P56074	H-0301-03	CL PIN 3/4"	1
3	P56110	H-0360-02	COTTER PIN HMP 3/4"	1
4	P56111	H-0360-03	COTTER PIN HMP 7/8"	1
5	P56159	H-0402-07	NUT HX JAM 7/8"	1
6	P57585	M-6378-01	YCC-65-BDY GALV	1

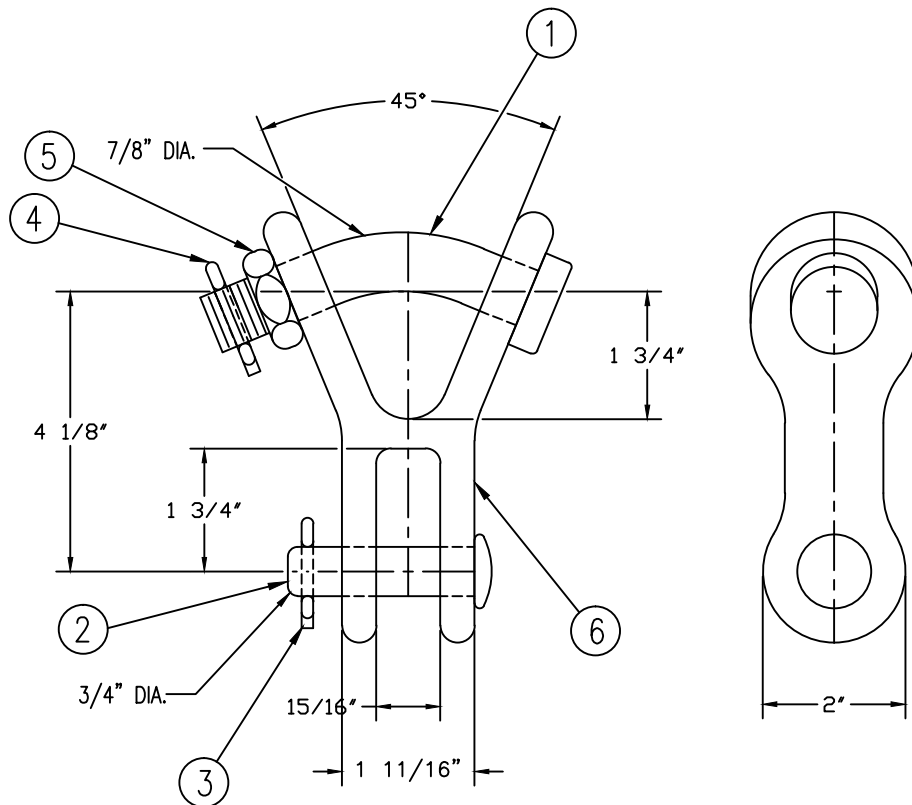

NOTES:

- MATERIAL:
  - BODY - DUCTILE IRON
  - COTTER PIN - AISI 302 STAINLESS STEEL
  - HARDWARE - STEEL, HOT DIP GALVANIZED
- FINISH: HOT DIP GALVANIZED PER ASTM A153
- ULTIMATE STRENGTH: 40,000 LBS.
- WEIGHT: 5.541 LBS.

NO.	DATE	DESCRIPTION	BY	CKD



**MACLEAN POWER SYSTEMS**  
A Maclean-fogg Company

YCC CLEVIS CLEVIS  
CATALOG NO: YCC-76

REVISIONS

DATE: 3/28/12	SCALE: NONE	NO. BC-8742-1	R / 0	SH.1 OF 1
BY: KH	BY: WCL	BY: WCL		