

ITEM NO.	PART NO.	CAT. NO.		QTY
1	P56058	H-0300-03	CL PIN 5/8"	1
2	P56109	H-0360-01	COTTER PN HMP 5/8"	1
3	P57077	H-0357-05	CEHL-55-687 GALV	1

REVISIONS				
NO.	DATE	DESCRIPTION	BY	CKD

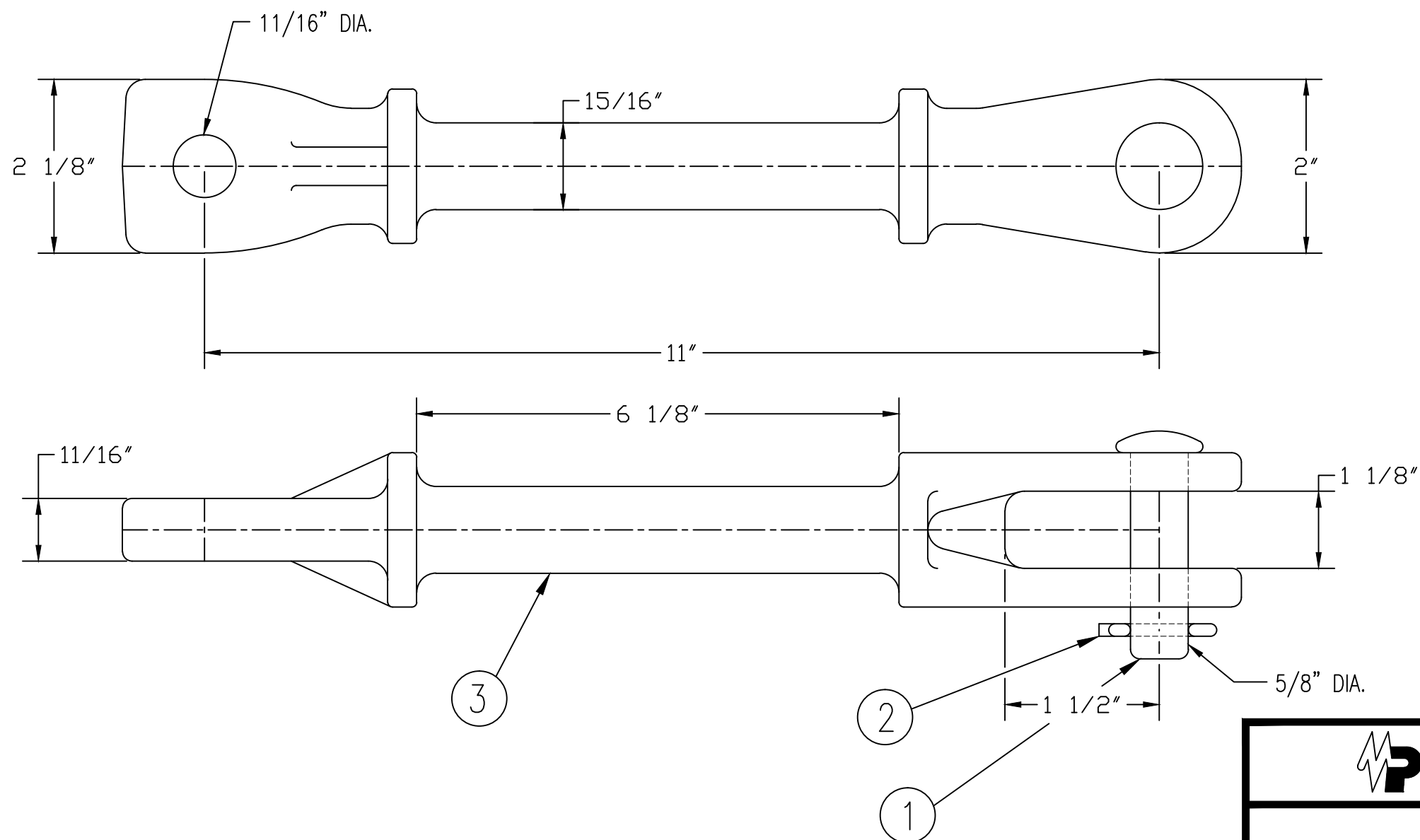

NOTES:

- MATERIAL:
 - BODY – DUCTILE IRON
 - COTTER PIN – AISI 302 STAINLESS STEEL
 - HARDWARE – STEEL, HOT DIP GALVANIZED
- FINISH: HOT DIP GALVANIZED PER ASTM A153
- ULTIMATE STRENGTH: 30,000 LBS.
- WEIGHT: 3.476 LBS.



MACLEAN POWER SYSTEMS
A Maclean-fogg Company

CEHL-CLEVIS EYE
CEHL 55-687

This information is confidential and is the property of Maclean Power Systems. It may not be made public or reproduced except that the Customer may make copies for use solely in instillation, maintenance, and operation of products supplied by Maclean Power Systems.

DATE: 3-27-12	SCALE: NONE	NO. BC-8748-2	R / 0	SH. 1 OF 1
DWN. BY: KH	CKD. BY: WCL	APR. BY: WCL		