

NO. BC-8765-1

ITEM NO.	PART NO.	CAT. NO.	DESCRIPTION	QTY
1	P55834	H-0100-02	7/8" BENT BOLT	1
2	P56111	H-0360-03	COTTER PN HMP 7/8"	1
3	P56159	H-0402-07	NUT HX JAM 7/8"	1
4	P59844	P-6103-02	RYCEHL-77-875 GAL	1

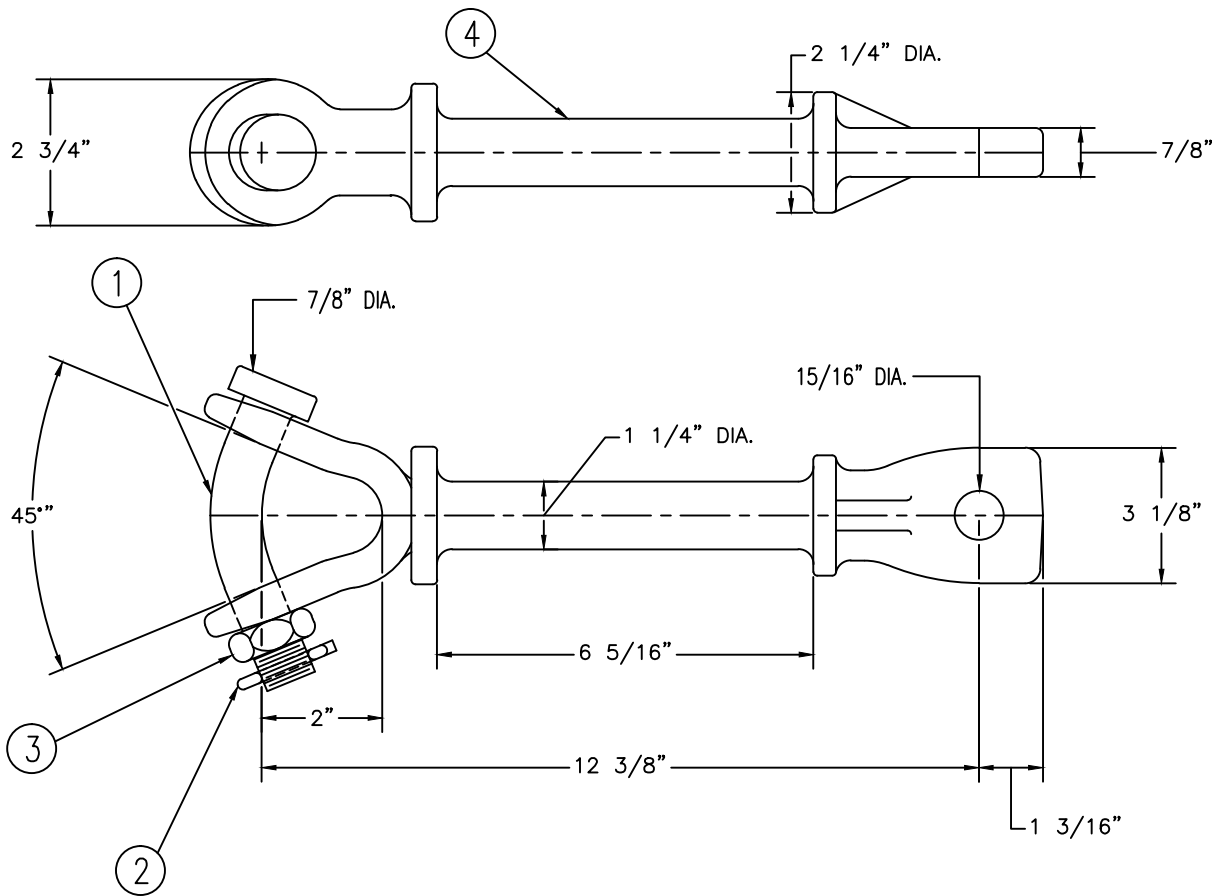

NOTES:

1. MATERIAL:
 - A. BODY - DUCTILE IRON
 - B. COTTER PIN - AISI 302 STAINLESS STEEL
 - C. HARDWARE - STEEL, HOT DIP GALVANIZED
2. FINISH: HOT DIP GALVANIZED PER ASTM A153
3. ULTIMATE STRENGTH: 50,000 LBS.
4. WEIGHT: N/A LBS.

This information is confidential and is the property of Maclean Power Systems. It may not be made public or reproduced except that the Customer may make copies for use solely in installation, maintenance, and operation of products supplied by Maclean Power Systems.



MACLEAN POWER SYSTEMS
A Maclean-fogg Company

RYCEHL - Y CLEVIS EYE
CATALOG NO: RYCEHL-77-875

NO.	DATE	REVISIONS	BY	CKD

DATE: 3/29/12	SCALE: NONE	NO. BC-8765-1	R/0	SH.1 OF 1
OWN: KH	BY: WCL	BY: WCL		