

NO. BC-8766-1

ITEM NO.	PART NO.	CAT. NO.	DESCRIPTION	QTY
1	P55833	H-0100-01	3/4" BENT BOLT	1
2	P56110	H-0360-02	COTTER PN HMP 3/4"	1
3	P56158	H-0402-06	NUT HX JAM 3/4"	1
4	P57410	M-0853-02	YCEHL-65-625 GALV	1

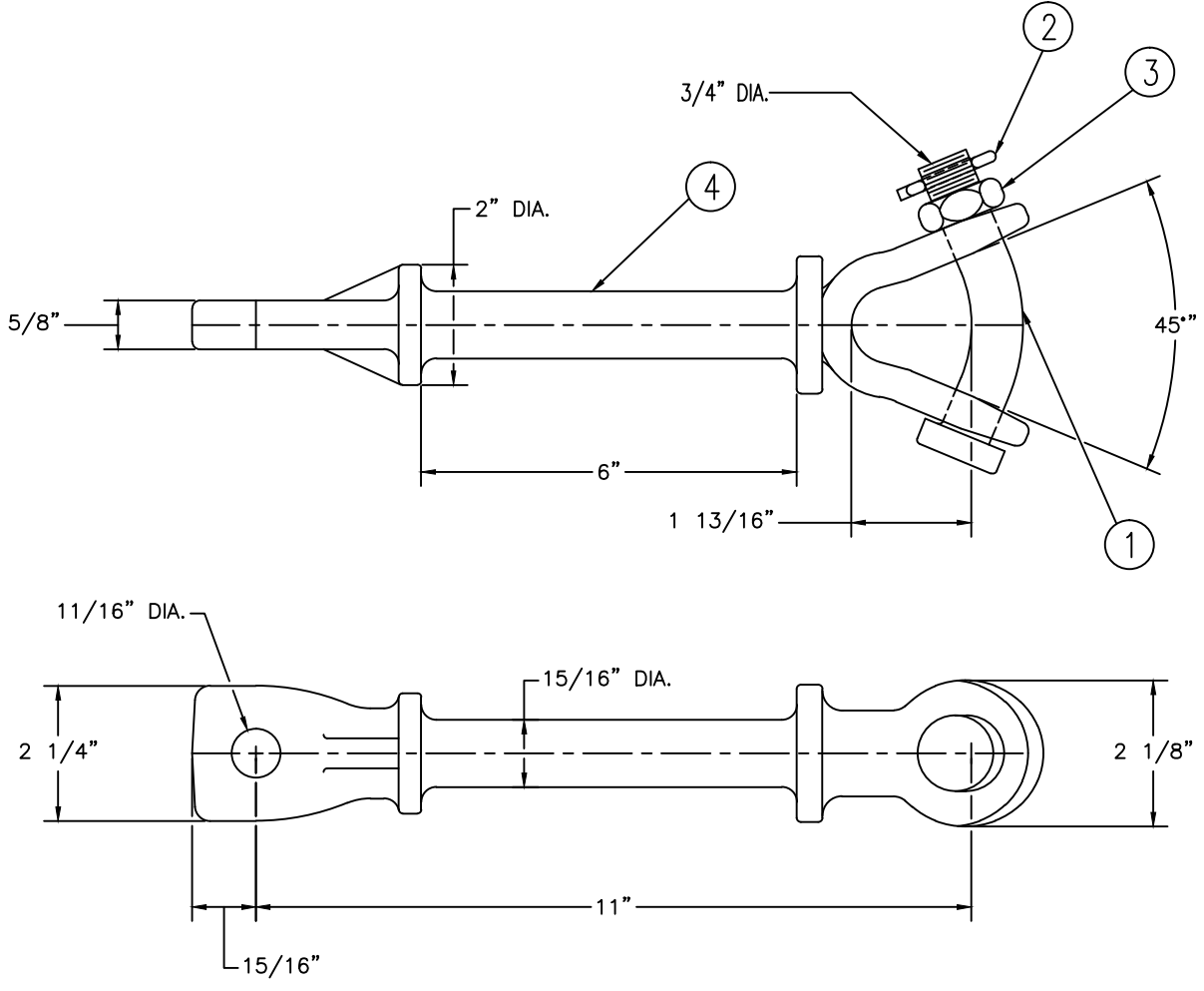

**NOTES:**

1. MATERIAL:
  - A. BODY - DUCTILE IRON
  - B. COTTER PIN - AISI 302 STAINLESS STEEL
  - C. HARDWARE - STEEL, HOT DIP GALVANIZED
2. FINISH: HOT DIP GALVANIZED PER ASTM A153
3. ULTIMATE STRENGTH: 30,000 LBS.
4. WEIGHT: 4.710 LBS.

This information is confidential and is the property of Maclean Power Systems. It may not be made public or reproduced except that the Customer may make copies for use solely in installation, maintenance, and operation of products supplied by Maclean Power Systems.



**YCEHL - Y CLEVIS EYE**  
**CATALOG NO: YCEHL 65-625**

NO.	DATE	REVISIONS	BY	CKD

DATE: 3/29/12	SCALE: NONE	NO. BC-8766-1	R/0	SH.1 OF 1
OWN. KH	BY: WCL	APR. WCL		