

2

1

B

B

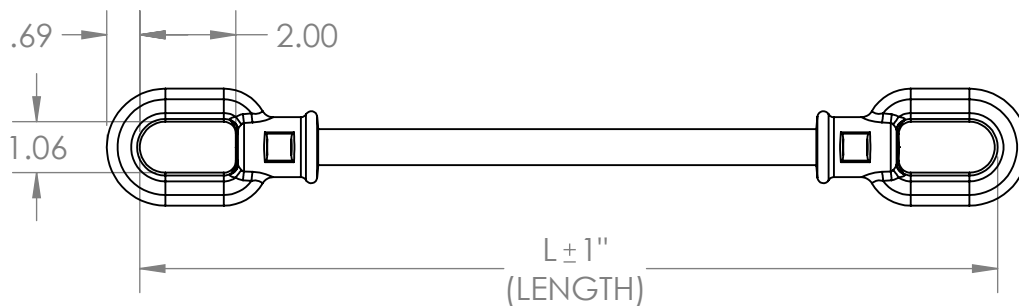
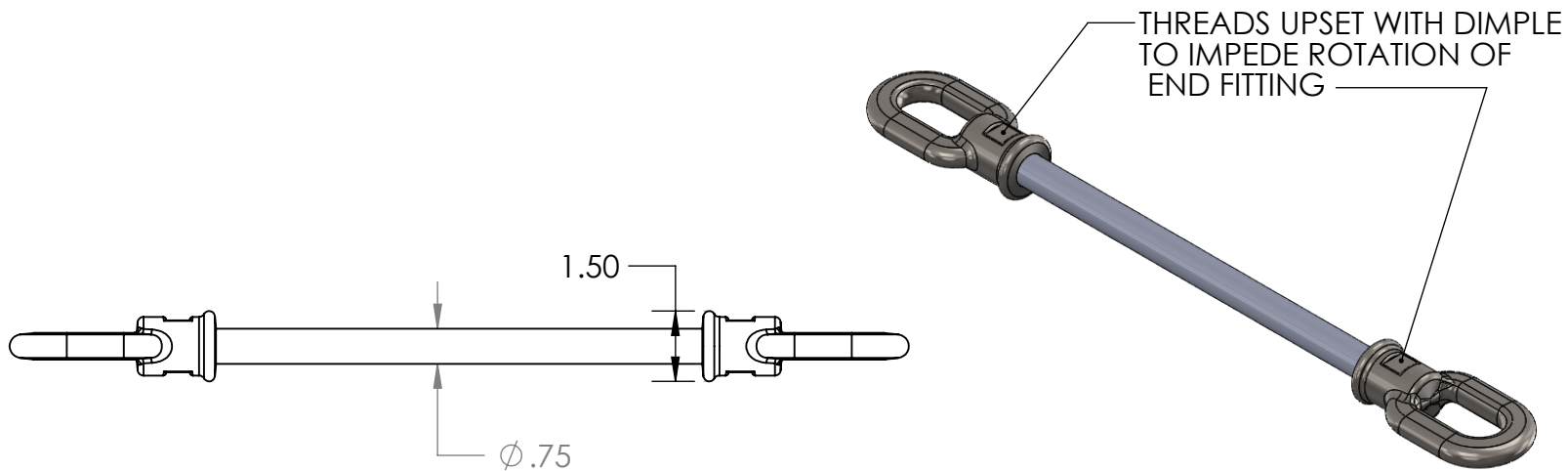

NOTE:

1. MATERIAL  
 -END FITTING - FORGED STEEL.  
 -  $\phi$  3/4" ROD - GRADE 5 STEEL.
2. FINISH - HOT DIP GALVANIZE PER ASTM A-153.
3. ULTIMATE STRENGTH - 36,000 LBS.

A

A

MACLEAN POWER SYSTEMS

OVAL EYE - OVAL EYE H.L. EXT.  
CAT. NO. LOO-36-L

	NAME	DATE
DRAWN	MBG	10/16/17
CHECKED		

PROPRIETARY AND CONFIDENTIAL

THE INFORMATION CONTAINED IN THIS DRAWING IS THE SOLE PROPERTY OF MACLEAN POWER SYSTEMS. ANY REPRODUCTION IN PART OR AS A WHOLE WITHOUT THE WRITTEN PERMISSION OF MACLEAN POWER SYSTEMS IS PROHIBITED.

DIMENSIONS ARE IN INCHES  
 TOLERANCES:  
 FRACTIONAL ±  
 ANGULAR: MACH ± BEND ±  
 TWO PLACE DECIMAL ±  
 THREE PLACE DECIMAL ±

SIZE	DWG. NO.	REV
<b>A</b>	BC8890-1	<b>0</b>

SCALE: 1:4 WEIGHT: SHEET 1 OF 1

2

1