

2

1

B

B

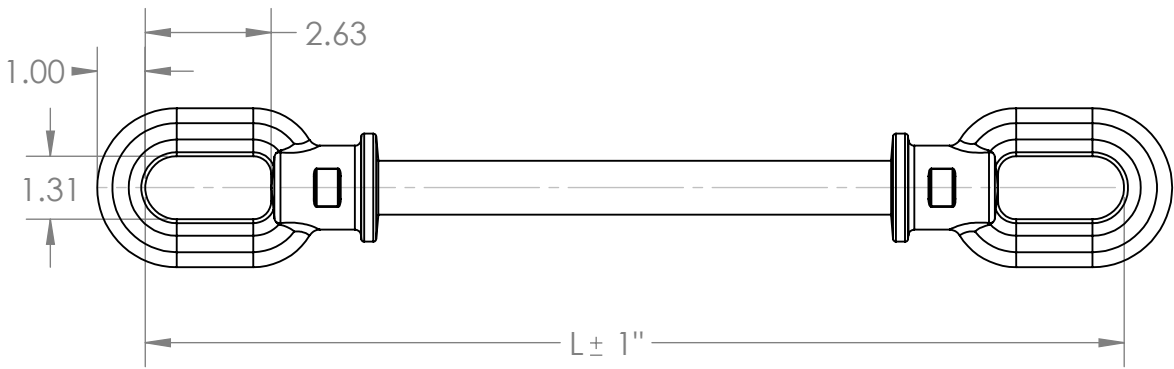
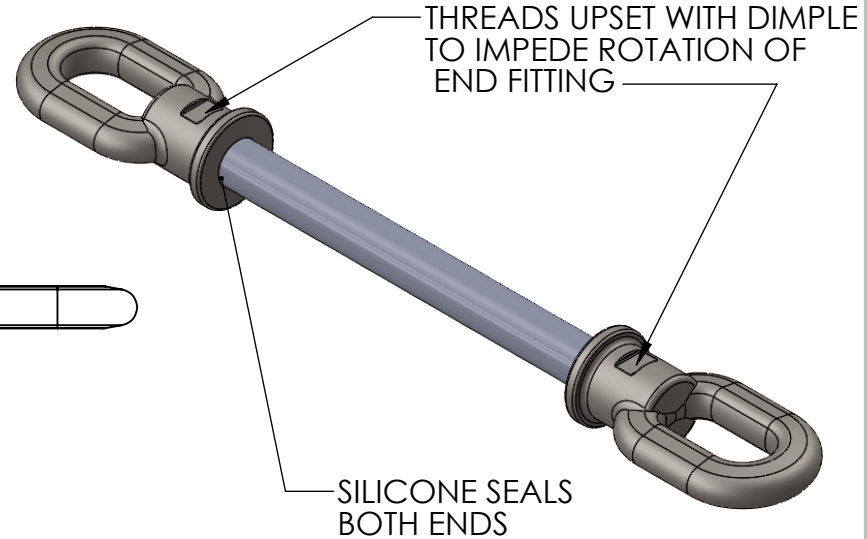
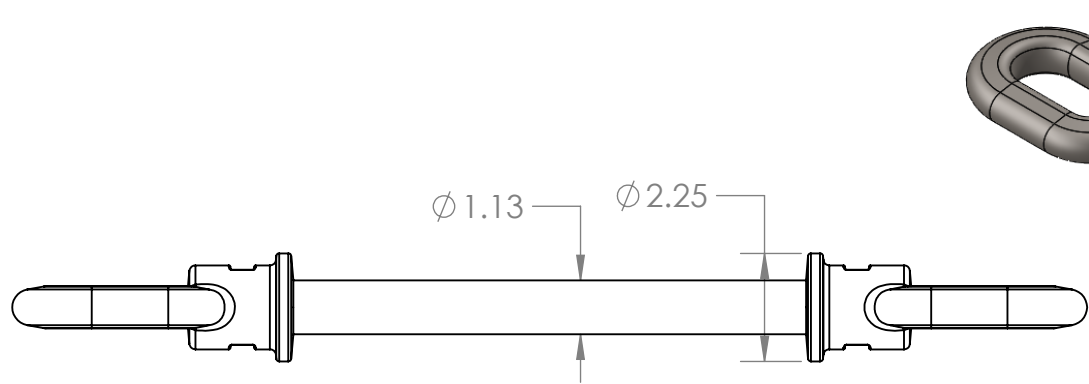

NOTE:

- 1. MATERIAL  
-END FITTING - FORGED STEEL.  
- $\phi$  1 1/8" ROD - GRADE 5 STEEL.
- 2. FINISH - HOT DIP GALVANIZE PER ASTM A-153.
- 3. ULTIMATE STRENGTH - 80,000 LBS.

A

A

MACLEAN POWER SYSTEMS

OVAL EYE - OVAL EYE H.L. EXT.  
CAT. NO. LOO-80-L

|         |      |          |
|---------|------|----------|
|         | NAME | DATE     |
| DRAWN   | BKS  | 06/01/18 |
| CHECKED |      |          |

**PROPRIETARY AND CONFIDENTIAL**

THE INFORMATION CONTAINED IN THIS DRAWING IS THE SOLE PROPERTY OF MACLEAN POWER SYSTEMS. ANY REPRODUCTION IN PART OR AS A WHOLE WITHOUT THE WRITTEN PERMISSION OF MACLEAN POWER SYSTEMS IS PROHIBITED.

DIMENSIONS ARE IN INCHES  
TOLERANCES:  
FRACTIONAL  $\pm$   
ANGULAR: MACH  $\pm$  BEND  $\pm$   
TWO PLACE DECIMAL  $\pm$   
THREE PLACE DECIMAL  $\pm$

|          |          |          |
|----------|----------|----------|
| SIZE     | DWG. NO. | REV      |
| <b>A</b> | BC8917-1 | <b>0</b> |

SCALE: 1:4 WEIGHT: SHEET 1 OF 1

2

1