

This information is confidential and is the property of Maclean Power Systems. It may not be made public or reproduced except that the Customer may make copies for use solely in installation, maintenance, and operation of products supplied by Maclean Power Systems.

NO. CEA-3626

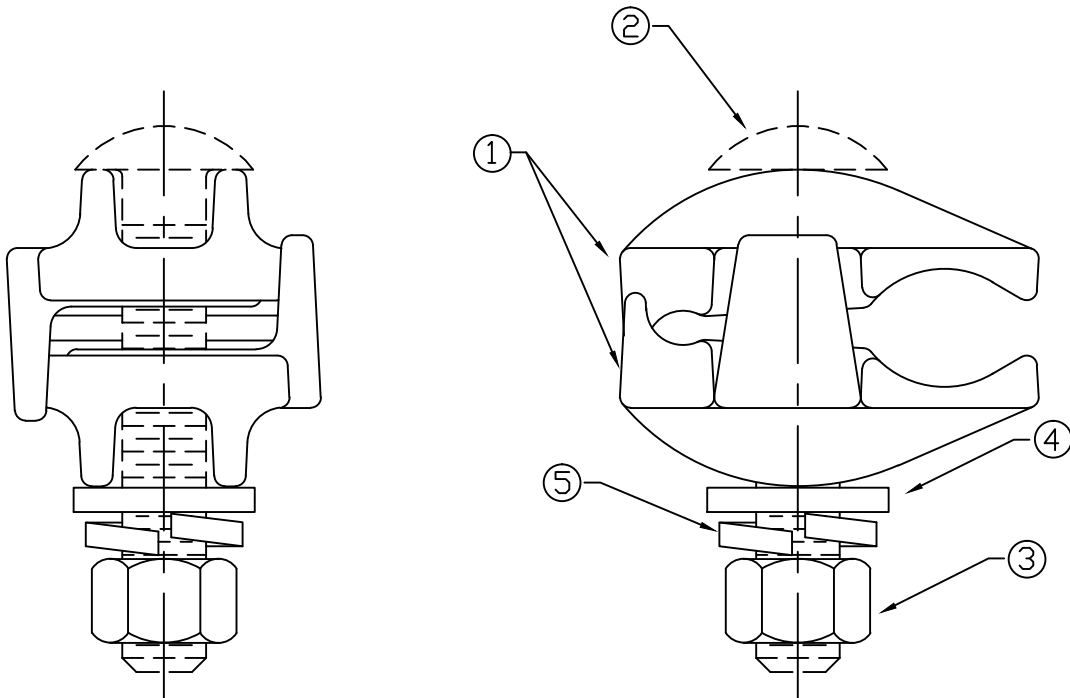

ITEM NO.	PART NO.	CAT. NO.		QTY
1	P64437C	>BC-105-BC	BC-105 casting	2
2	P55848	H-0123-04	1/2"X3" CARRIAGE BOLT, GR.5	1
3	P56137	H-0400-04	1/2"-13 HEX NUT	1
4	P56294	H-0500-04	1/2" FLAT WASHER	1
5	P56399	H-0520-04	1/2"LUCK WASHER	1

NOTES:

- 1. MATERIAL - BODY AND KEEPER: DUCTILE IRON.
HOT DIP GALV. PER ASTM-A153
HARDWARE: STEEL, HOT DIP GALV. PER ASTM-A153
- 2. CLAMPING RANGE - MAIN: 0.5" - 1.0".
TAP: 0.16" - 0.46".

NO.	DATE	DESCRIPTION	BY	CKD

MACLEAN POWER SYSTEMS
A Maclean-fogg Company

BONDING CLAMP
CATALOG NUMBER: BC-105

REVISIONS

DATE: 7/05/13	SCALE: NONE	NO. CEA-3626	R / 0	SH.1 OF 1
BY: LMV	BY: WCL	BY: WCL		