

REVISIONS				
NO.	DATE	DESCRIPTION	BY	CKD

NOTES:

- 1.0 MATERIAL—DUCTILE IRON PER ASTM A-536,  
HOT DIP GALVANIZED PER ASTM A-153.  
HARDWARE — STEEL, HOT DIP GALV.  
COTTER KEY — SS STEEL.
- 2.0 WEIGHT — 5.70 LBS.
- 3.0 DIMENSION IN INCHES.

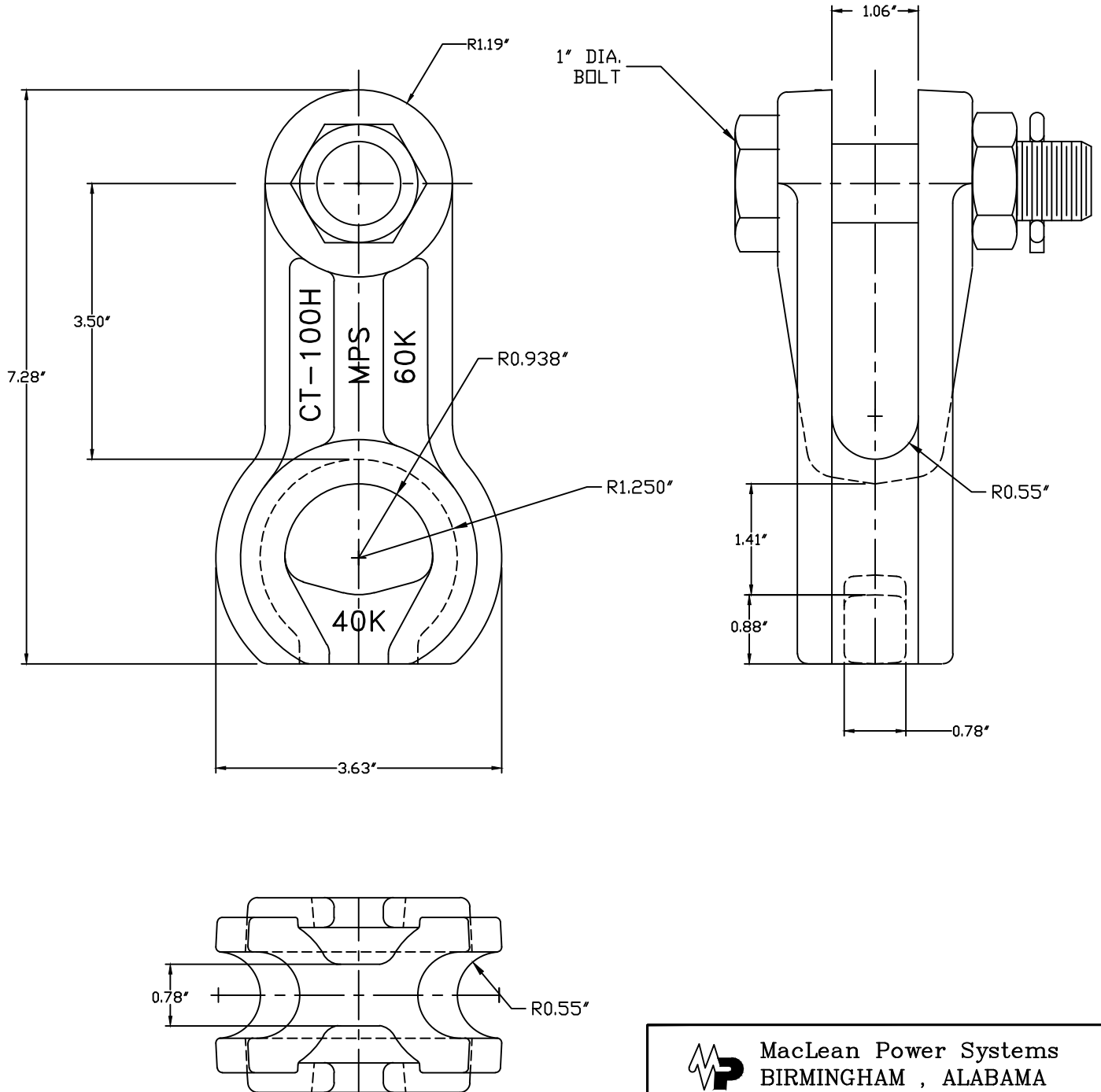

ENG. REF.

This information is confidential and is the property of Maclean Power Systems. It may not be made public or reproduced except that the Customer may make copies for use solely in installation, maintenance, and operation of products supplied by Maclean Power Systems.

 <b>Maclean Power Systems</b> <b>BIRMINGHAM , ALABAMA</b>		
DRAWN BY: KMK	APPROVED BY: _____ CHECKED BY: _____	SCALE: NONE
<b>DEADEND THIMBLE</b> <b>CT-100H</b>		
DATE: 4/27/10	DRAWING NO: CEB-1153	R / 0