

REVISONS		DESCRIPTION	BY	OKD
NO.	DATE			
1	6/28/21	ADDED BOM TABLE	EDB	
2	6/05/23	UPDATED TO MATCH CASTING DIM	WCL	

ITEM NO.	PART NO.	CAT. NO.	DESCRIPTION	DWG. NO.
1	P63700C	P135AXW-BC	JS-GA-5X BLK	PB2097C

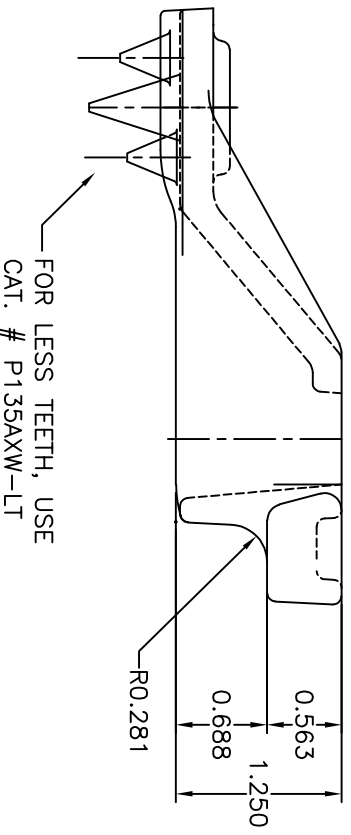
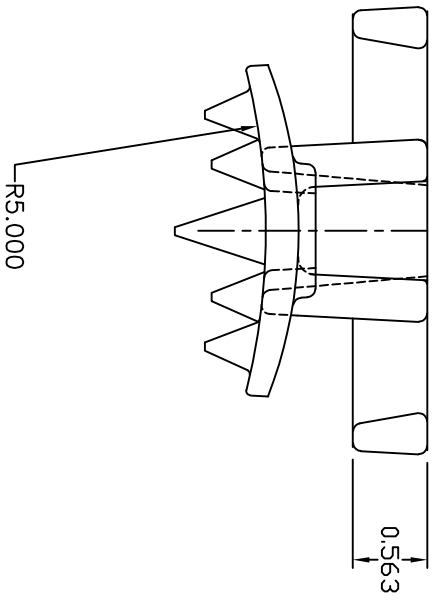
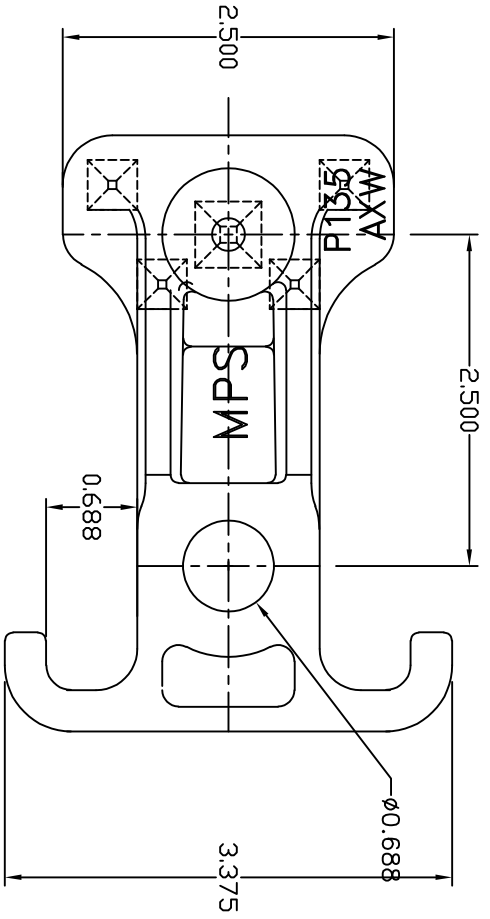

NOTES:

- 1.0 MATERIAL-DUCTILE IRON PER ASTM A-536,
- 2.0 COATING-HOT DIP GALVANIZE PER ASTM A-153.
- 3.0 PART NO. - P135AXW, (F3922695)
- 4.0 EST. WEIGHT - 0.86 LBS.
- 5.0 DIMENSION IN INCHES.

ENG. REF.

This information is confidential and is the property of Maclean Power Systems. It may not be made public or reproduced except that the customer may make copies for use only in installation, maintenance, and operation of products supplied by Maclean Power Systems.



Maclean Power Systems
BIRMINGHAM, ALABAMA

DATE: 06/04/13

DRAWING NO: CEB-4132

DRAWN BY: LMV	APPROVED BY: WCL	SCALE: 1"=1"
	CHECKED BY: KMK	

GUY HOOK, P135AXW & P135AXW-LT
Rated Strength: 13,550 Lbs.

R/2