

REVISIONS

NO.	DATE	DESCRIPTION	BY	CKD
1	6/28/21	ADDED BOM TABLE	EDB	CKD

ITEM NO.	PART NO.	CAT NO.	DESCRIPTION	DWG. NO.
1	P64507G	CW-35-7-G	CW-35-7 BDY	PB2184

NOTES:

- 1.0 MATERIAL-DUCTILE IRON PER ASTM A-536,
- 2.0 COATING-HOT DIP GALVANIZE PER ASTM A-153.
- 3.0 PART NO. -CW35-7, (F411260)
- 4.0 EST. WEIGHT -1.24 LBS.
- 5.0 DIMENSION IN INCHES.

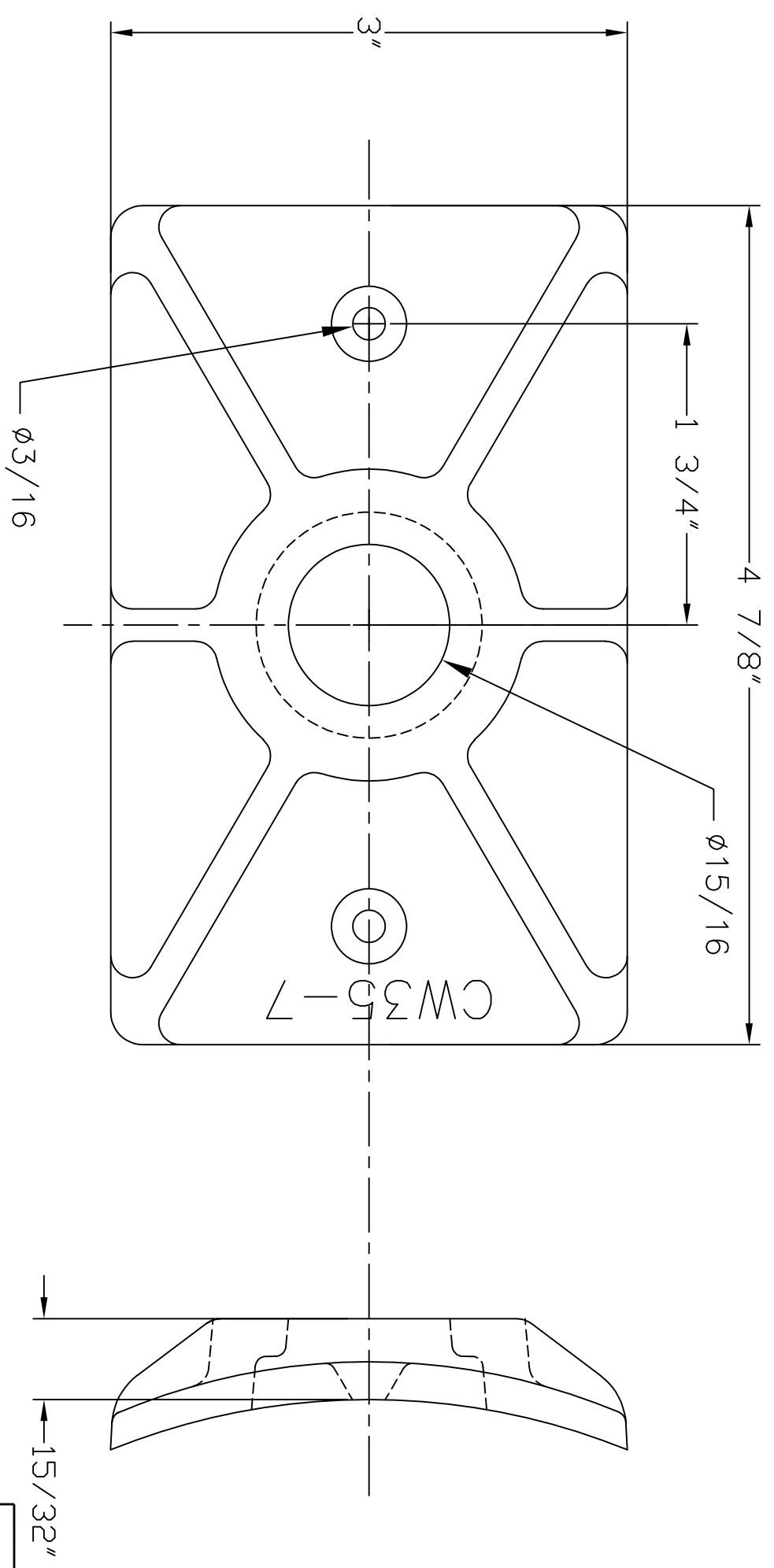

ENG. REF.

This information is confidential and is the property of Maclean Power Systems. It may not be made public or reproduced except that the Customer may make copies for use solely in installation, maintenance, and operation of products supplied by Maclean Power Systems.

 <b>Maclean Power Systems</b> BIRMINGHAM, ALABAMA	
DRAWN BY: KMK APPROVED BY: WCL CHECKED BY:	SCALE: 1"=1"
CURVE WASHER CAT. NO.: CW-35-7	
DATE: 9/21/23	DRAWING NO: CEB-4667

R/0