

4

3

2

1

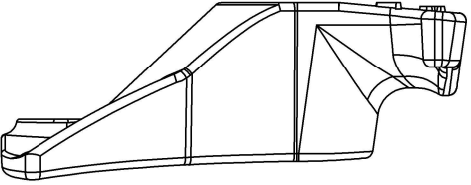
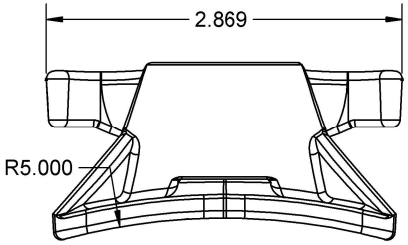
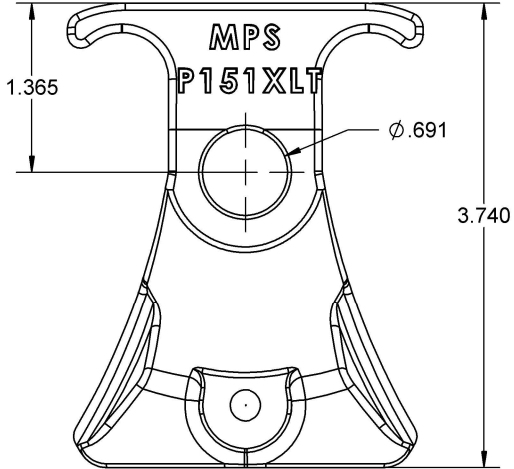

- NOTES:
1. MATERIAL: DUCTILE IRON PER ASTM A-536.
 2. COATING: HOT DIP GALVANIZE PER ASTM A-153.
 3. ESTIMATED WEIGHT: 0.77 LBS.
 4. DIMENSIONS ARE IN INCHES.
 5. STRENGTH RATING: 13,550 LBS

PROJECT NAME		PART NUMBER		F344045		MACLEAN POWER SYSTEMS			
ECO NUMBER		MATERIAL		Ductile Iron					
STRENGTH RATING 13,550 LBS		FINISH		Galvanized		DESCRIPTION POLE LINE HARDWARE GUY HOOK LESS TEETH P151XLT			
		CABLE RANGE IN		WEIGHT 0.73 LBS					
REASON FOR CHANGE CREATING CUSTOMER DRAWING		DRAWN BY		HMG				DATE	
		ENGINEERING		HMG				01/19/2026	
		TOOLING				SIZE			
		TOLERANCES				DWG. NO.		REV	
		XX +/-0.08		X/XX +/-1/32		EA-344045			
Original Drawn By		Original Drawn Date		XX +/-0.031		ANGLES +/-1°			
				SCALE: 1:1		OLD DRAWING #			
						SHEET 1 OF 1			

4

3

2

1