

ITEM NO.	DESCRIPTION	MATERIAL	QTY.
1	TUBE	ALUMINUM ALLOY	1
2	JAWS 81 PLTD (NOT SHOWN)	PLATED STEEL	3
3	WASHER PLTD (NOT SHOWN)	PLATED STEEL	1
4	SPRING (NOT SHOWN)	GALVANIZED STEEL	1
5	YOKE	ALUMINUM ALLOY	1

PAPER SIZE		CATALOG NUMBER	
<b>B</b>		<b>5056</b>	
REV	REVISED BY	REVISION DATE	ECO #
A	MIT	06-11-19	D9557

**NOTES:**

1. WIRE RANGE:  
0.062" - 0.100 "  
14 BWG OR  
12 AWG

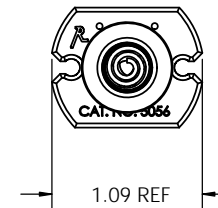
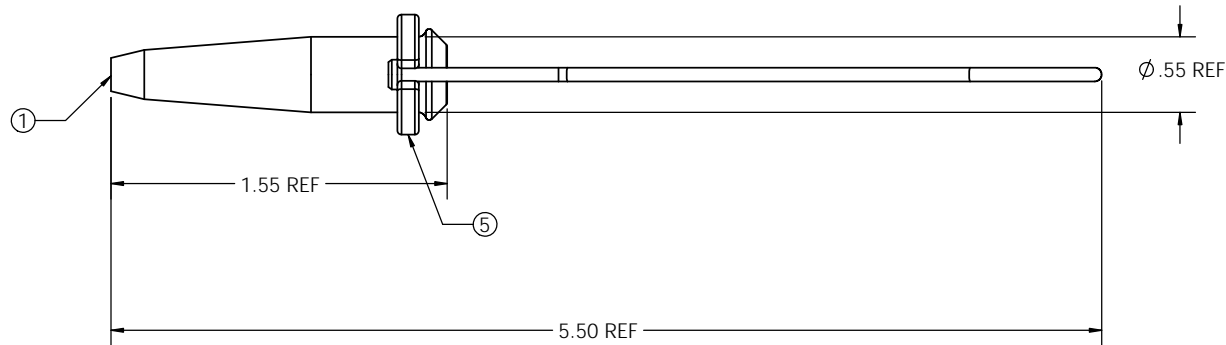
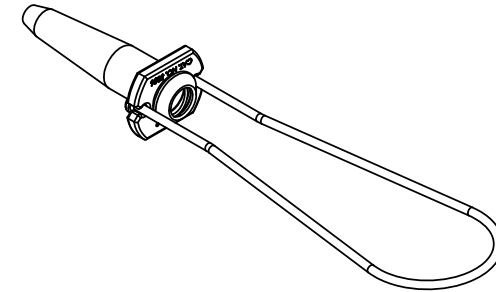

CATALOG #	5056
-----------	------

This drawing contains confidential information that is the property of MacLean Power, L.L.C. ("MacLean"). Use of MacLean's confidential information without MacLean's express written consent is strictly prohibited and may expose you to legal liability. If you believe that you received this material in error, please destroy it or return it to "MacLean Power, L.L.C., 481 Munn Rd, Suite 300, Fort Mill, SC 29715 USA."



DRAWING NUMBER:	
<b>GD-5056</b>	
SHEET NAME:	1 OF 1
Sheet1	
DRAWING DESCRIPTION:	
5056 WIREVISE WITH BAIL	
DRAWN BY:	DESIGN DATE:
MIT	11/15/01