

PAPER SIZE		CATALOG NUMBER	
B		GD-5200	
REV	REVISED BY	REVISION DATE	ECO #
A	SJL	01-15-20	D9044

RATED TO HOLD A MINIMUM OF 90% OF RBS OF APPROVED STRANDS.

APPROVED STRANDS:
 1/4" OR 7/32" STEEL STR. RANGE .215 - .270 DIA.
 ALWD 3#10 & 3#9 & 7#12 (6M)
 ALUMINUM COVERED OR GALVANIZED

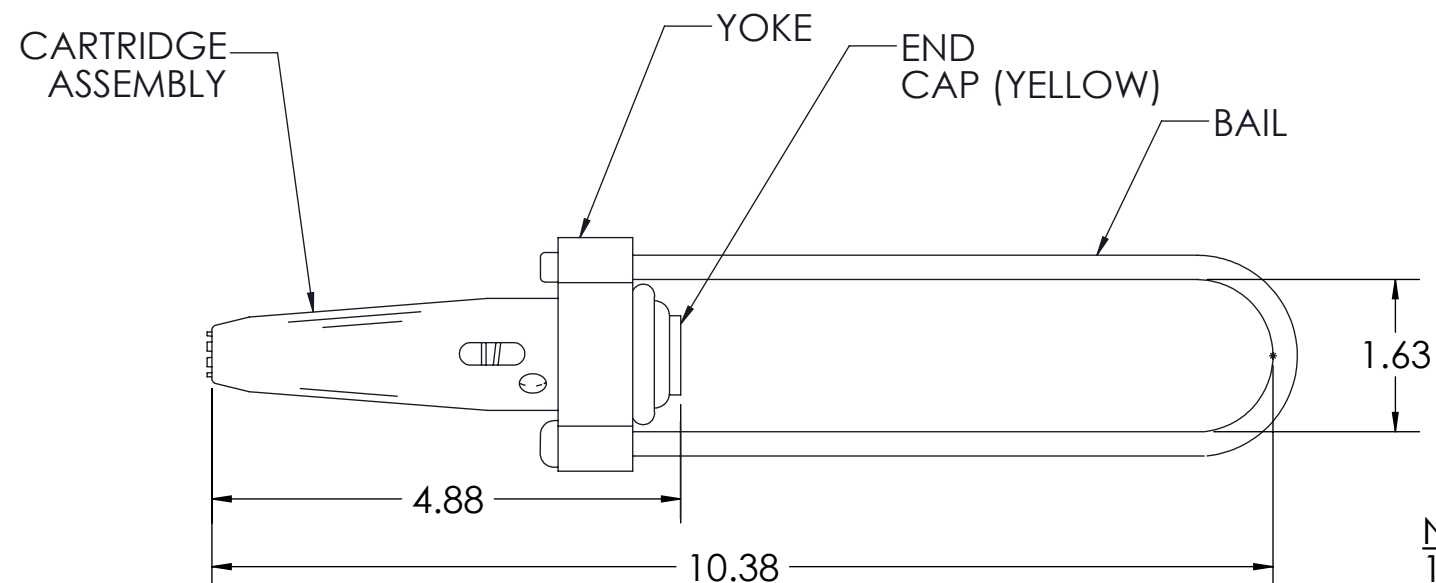

NOTES:

1. ALL DIMENSIONS ARE REFERENCE AND IN INCHES.
2. MATERIALS: YOKE-ALUMINUM, BAIL-STAINLESS STEEL

CARTRIDGE ASSEMBLY MATERIAL:

TUBING: ALUMINUM ALLOY
 JAWS: CHROMATE PLATED STEEL
 PILOT CUP: PLATED STEEL
 WASHER: PLATED STEEL
 END CAP: PLASTIC (YELLOW)

This drawing contains confidential information that is the property of MacLean Power, L.L.C. ("MacLean"). Use of MacLean's confidential information without MacLean's express written consent is strictly prohibited and may expose you to legal liability. If you believe that you received this material in error, please destroy it or return it to "MacLean Power, L.L.C., 481 Munn Rd, Suite 300, Fort Mill, SC 29715 USA."



DRAWING NUMBER:	
GD-5200	
SHEET NAME:	1 OF 1
GD-5200	
DRAWING DESCRIPTION:	
1/4 UNIVERSAL GRADE STRANDVISE	
DRAWN BY: SJL	DESIGN DATE: 03-13-13