

PAPER SIZE	DRAWING NUMBER	
A SIZE	GD-5201	
REV	REVISION DATE	ECO
A	03-04-10	9873

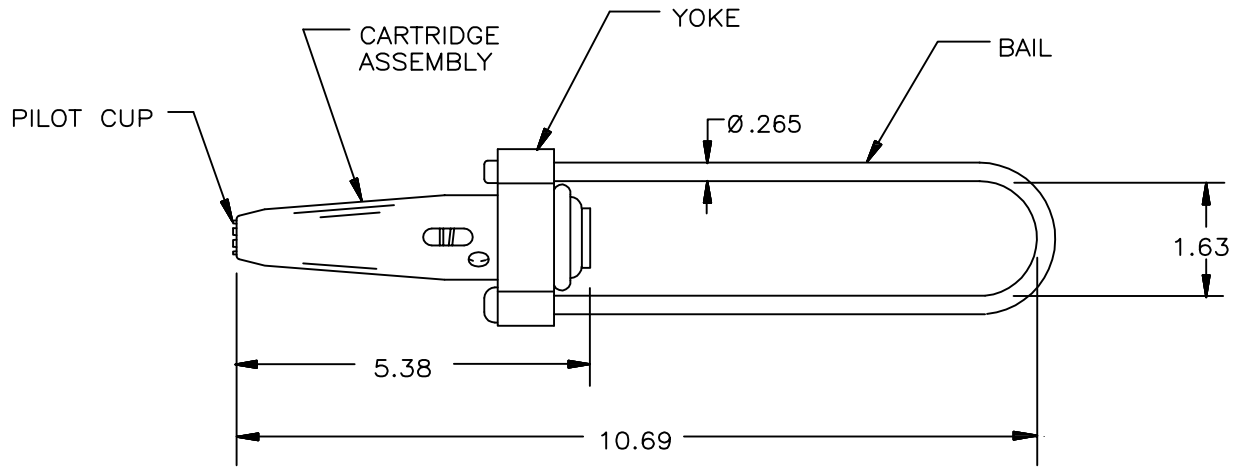

CATALOG NO. 5201

MATERIAL:

BAIL: STAINLESS STEEL

YOKE: ALUMINUM

CARTRIDGE ASSEMBLY:

JAWS: STEEL – HARDENED; ZINC AND CHROMATE PLATED

TUBING: ALUMINUM ALLOY

PILOT CUP: PLATED STEEL

SPRINGS: HARD DRAWN STEEL SPRING WIRE, GALVANIZED

WASHER: STEEL – ELECTRO PLATED

USE OR REPRODUCTION OF THIS DRAWING FOR THE PURPOSE OF MANUFACTURING THIS ARTICLE OR ARTICLES SHOWN OR ANY OTHER PURPOSE IS STRICTLY PROHIBITED EXCEPT ON WRITTEN PERMISSION.

MACLEAN POWER SYSTEMS

DRAWING-COMPUTER LOCATION

TOLERANCES UNLESS SPECIFIED		 <p>MACLEAN POWER SYSTEMS RELIABLE POWER PRODUCTS 11411 ADDISON STREET FRANKLIN PARK, IL. 60131</p>	DRAWN BY	ENGINEER	CHECKER	CATALOG #	SCALE	DESIGN DATE
INCH[mm]			MM	MM	FJS	5201	NA	03-04-10
0.XX	± [±]		DRAWING TITLE / DESCRIPTION					DRAWING NUMBER
0.XXX	± [±]		5/16 UN STRANDWISE					GD-5201
ANGLE	±							