

PAPER SIZE		DRAWING NUMBER	
A		GD-7652-53	
ISS	REVISED BY:	REVISION DATE	ECO #
B	PDR	02-10-12	10506

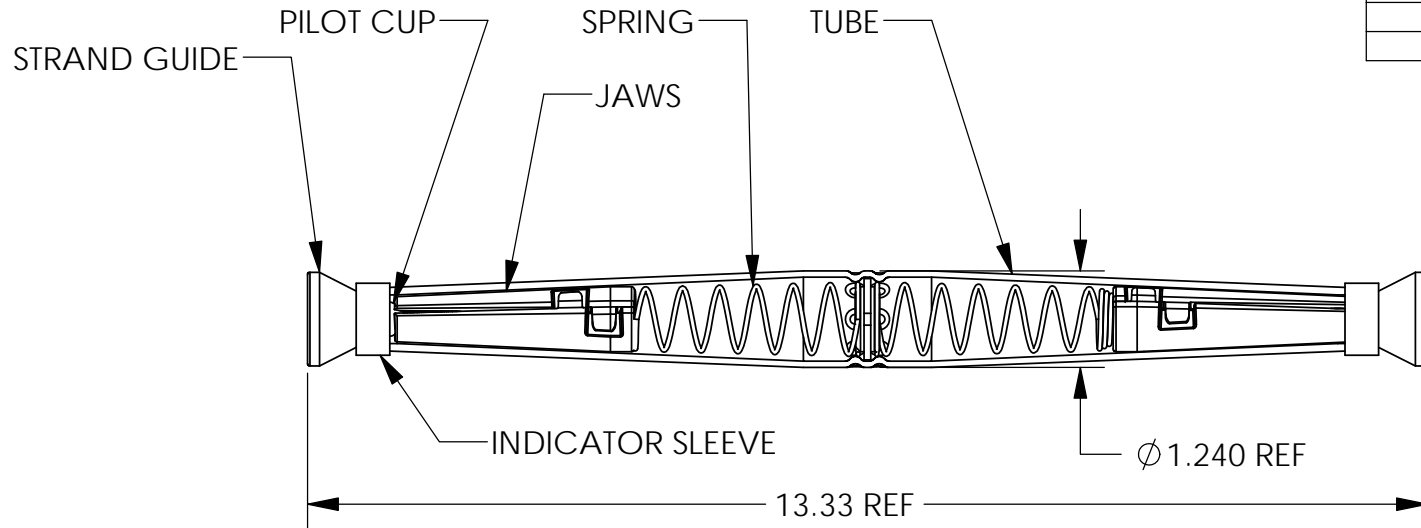

7652 PORTION SMALL END

7653 PORTION LARGE END

SMALL END 7652				LARGE END 7653				STANDARD PACK
ACSR ASTM-B232	AAAC ASTM-B399	AAC ASTM-B231	CONDUCTOR DIAMETER RANGE	ACSR ASTM-B232	AAAC ASTM-B399	AAC ASTM-B231	CONDUCTOR DIAMETER RANGE	
#2 & #4	#2 & #4	#2 & #4	.229-.340	1/0	1/0	1/0 & 2/0	.365-.425	25

**MATERIAL:**

- JAWS - DIE CAST ALUMINUM ALLOY
- TUBING - ALUMINUM ALLOY
- PILOT CUP - PLATED STEEL OR ALUMINUM
- SPRINGS - GALVANIZED STEEL
- STRANDGUIDE - PLASTIC (RED) 7652 PORTION
- STRANDGUIDE - PLASTIC (YELLOW) 7653 PORTION
- CENTER BARRIER - PLATED STEEL
- INDICATOR SLEEVE - PLASTIC (ORANGE)

CATALOG NO.: 7652-53

This drawing contains confidential information that is the property of MacLean Power, L.L.C. ("MacLean"). Use of MacLean's confidential information without MacLean's express written consent is strictly prohibited and may expose you to legal liability. If you believe that you received this material in error, please destroy it or return it to "MacLean Power, L.L.C., 11411 Addison Street, Franklin Park, Illinois 60131, USA."

UNLESS OTHERWISE SPECIFIED DIMENSIONS ARE IN: <b>INCHES</b>	
TOLERANCES ARE :	
.XX	----



**MACLEAN  
POWER  
SYSTEMS**  
11411 ADDISON STREET  
FRANKLIN PARK, IL. 60131

TEL. (847) 455-0014 FAX: (847) 455-0029

DRAWING NUMBER <b>GD-7652-53</b>		DO NOT SCALE DRAWING	
SHEET NAME: <b>7652-53</b>		1 OF 1	
DRAWING DESCRIPTION 7652-53 AUTOMATIC ACSR		CAD GENERATED DRAWING DO NOT MANUALLY UPDATE	
- TENSION SPLICE (USED ON F044176)		DESIGN DATE: <b>06-13-03</b>	
DWG SCALE: 1:2		DRAWN BY:	KCK
		ENGINEER	EMG
		APPROVED	FJS