

A

B

PAPER SIZE	DRAWING NUMBER	
A SIZE	GD-7654AP LD	
REV	REVISION DATE	ECO
A	05-17-16	12201

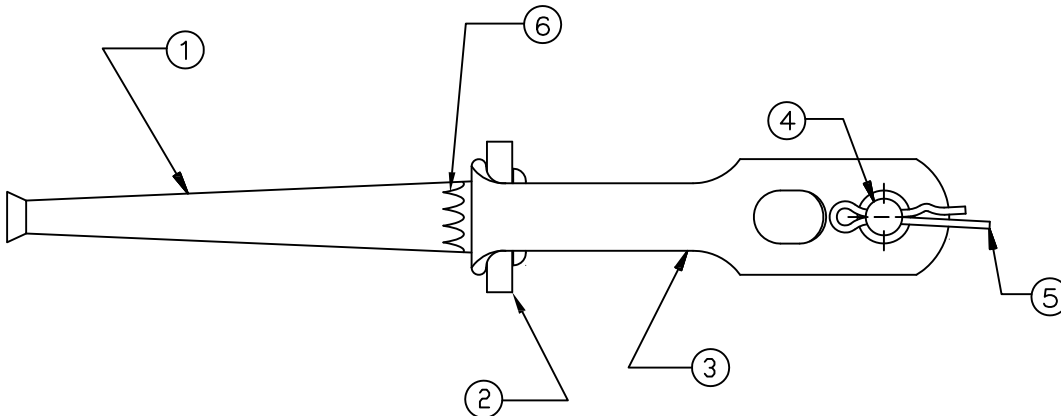
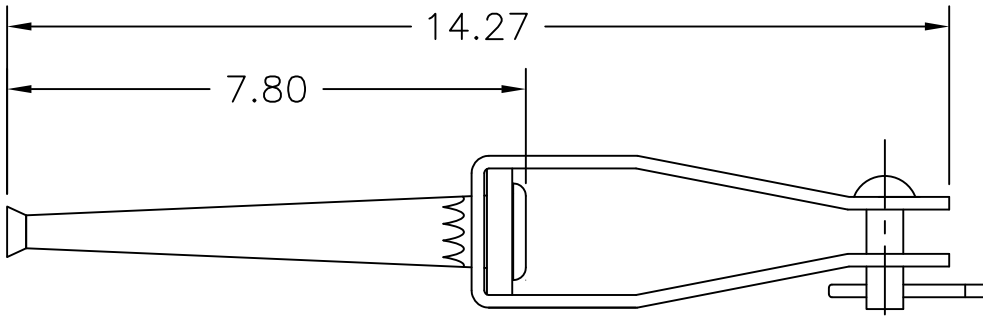

ITEM	DESCRIPTION	MATERIAL
1	CARTRIDGE ASSEMBLY	TUBING: ALUMINUM ALLOY JAWS: ALUMINUM ALLOY PILOT CUP: PLATED STEEL SPRINGS: GALVANIZED STEEL STRANDGUIDE: PLASTIC
2	YOKE	ALUMINUM
3	CLEVIS	GALVANIZED STEEL
4	CLEVIS PIN, $\phi.625$	GALVANIZED STEEL
5	COTTER PIN	STAINLESS STEEL
6	RETAINING WASHER	STAINLESS STEEL

CATALOG #	ACSR	AAAC	AAC
7654 AP LD	1/0 & 2/0	1/0 & 2/0	1/0, 2/0, & 3/0

NOTES:

1) ALL DIMENSIONS ARE REFERENCE AND IN INCHES.

This drawing contains confidential information that is the property of MacLean Power, L.L.C. ("MacLean"). Use of MacLean's confidential information without MacLean's express written consent is strictly prohibited and may expose you to legal liability. If you believe that you received this material in error, please destroy it or return it to "MacLean Power, L.L.C., 11411 Addison, Franklin Park, Illinois 60131, USA."

DRAWING-COMPUTER LOCATION
DRAWING-COMPUTER LOCATION

TOLERANCES UNLESS SPECIFIED	
INCH	
0.XX	— — —
0.XXX	— — —
ANGLE	— — —



**MACLEAN
POWER
SYSTEMS**
11411 ADDISON STREET
FRANKLIN PARK, IL 60131

DRAWN BY	ENGINEER	CHECKER	CATALOG #	SCALE	DESIGN DATE
SG	SG		7654AP LD	NTS	05-17-16
DRAWING TITLE / DESCRIPTION					DRAWING NUMBER
DEADEND					GD-7654AP LD