

PAPER SIZE		CATALOG NUMBER	
B		7656AP FDS	
REV	REVISED BY	REVISION DATE	ECO #
	AR	01-04-18	D8924

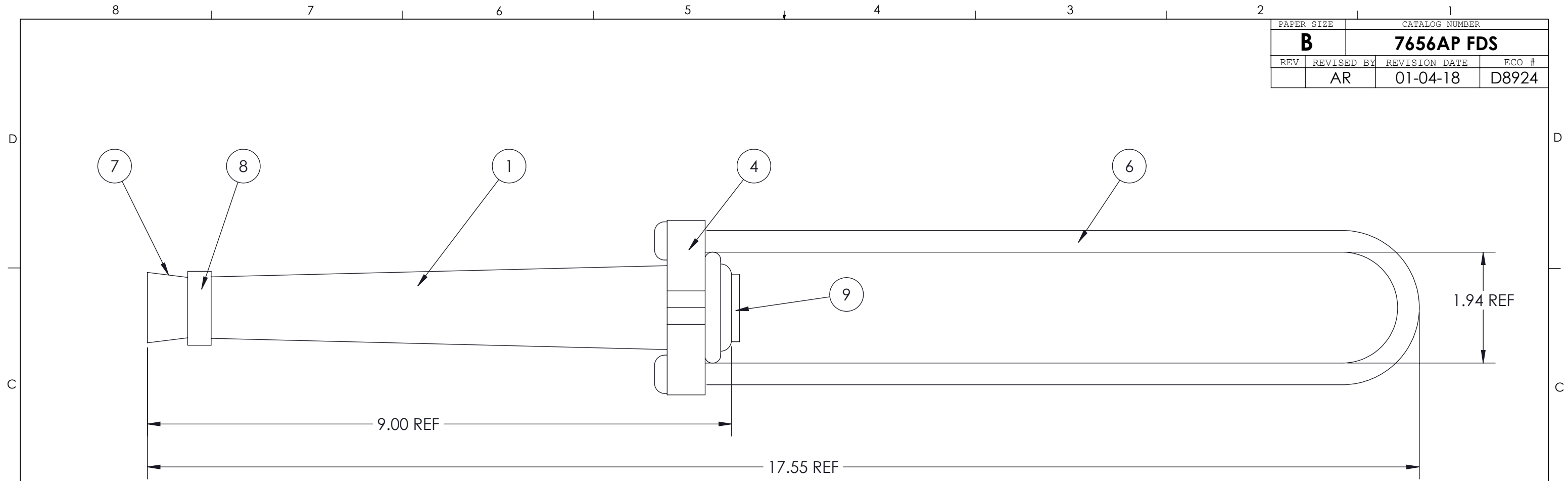

WIRE RANGE	
ACSR ASTM-B232	3/0 & 4/0
AAAC ASTM-B399	3/0 & 4/0
AAC ASTM-B231	4/0
DIAMETER RANGE	.502 - .585

ITEM #	DESCRIPTION	MATERIAL	QUANTITY
1	TUBE	ALUMINUM ALLOY	1
2	JAW	DIE CAST ALUMINUM ALLOY	2
3	SPRING	GALVANIZED STEEL	1
4	YOKE	ALUMINUM	1
5	PILOT CUP	ALUMINUM	1
6	FDS BAIL	STAINLESS STEEL	1
7	STRANDGUIDE	PLASTIC (PINK)	1
8	INDICATOR SLEEVE	PLASTIC (BLACK)	1
9	END PLUG	PLASTIC (BLUE)	1

Notes:
All dimensions are in inches.
All dimensions are reference.
Standard pack is 25.

This drawing contains confidential information that is the property of MacLean Power, L.L.C. ("MacLean"). Use of MacLean's confidential information without MacLean's express written consent is strictly prohibited and may expose you to legal liability. If you believe that you received this material in error, please destroy it or return it to "MacLean Power, L.L.C., 481 Munn Rd, Suite 300, Fort Mill, SC 29715 USA."



DRAWING NUMBER:	
GD-7656AP FDS	
SHEET NAME:	1 OF 1
Sheet1	
DRAWING DESCRIPTION:	
CONDUCTRWISE	
DRAWN BY:	DESIGN DATE:
AR	01-04-18