

PAPER SIZE		DRAWING NUMBER	
B		GD-9055	
REV	REVISED BY	REVISION DATE	ECO #
A	CAN	12/2/16	12359

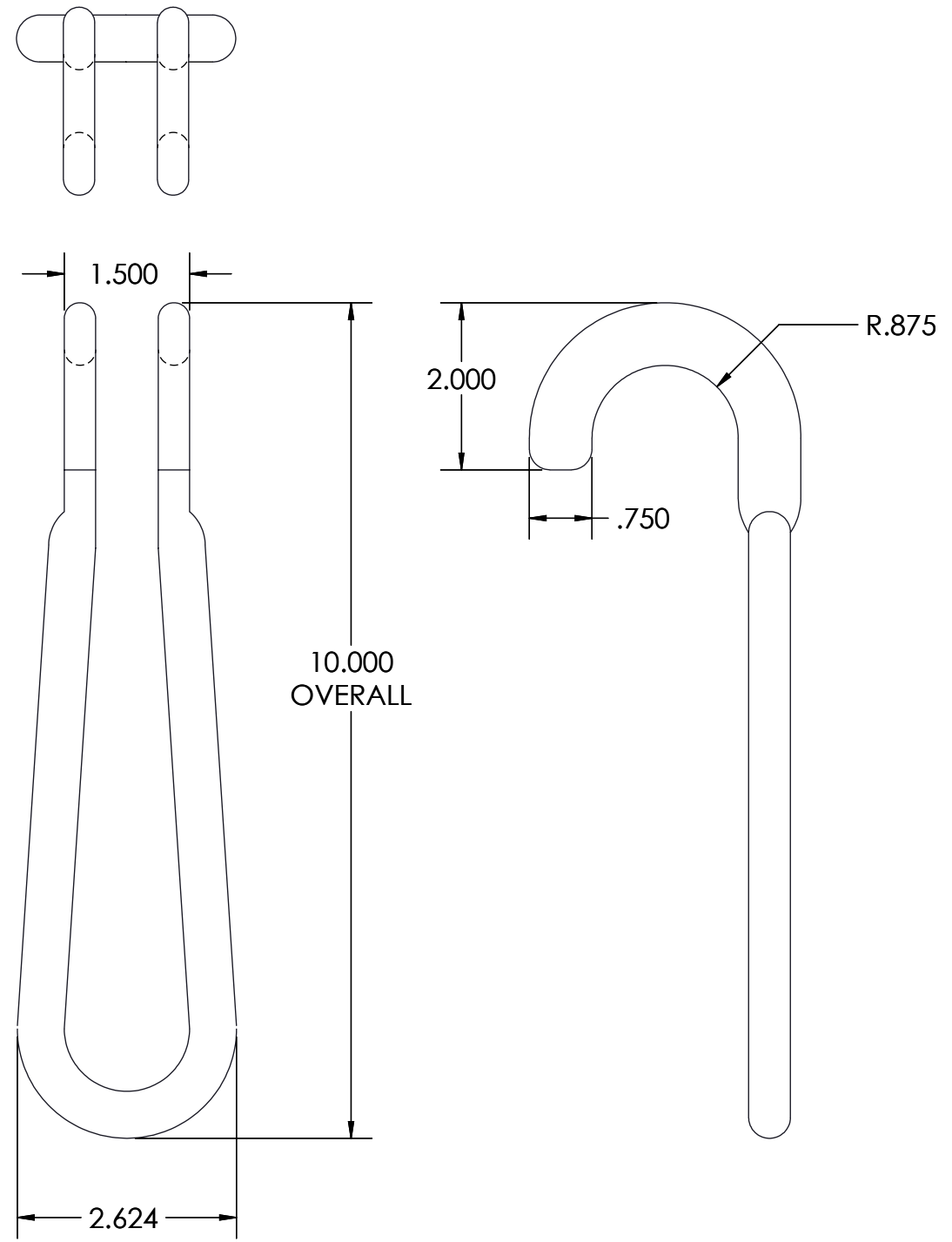

- NOTES:
1. MATERIAL: STEEL
 2. ZINC COATED PER ASTM A153 OR ASTM B695.
 3. ALL DIMENSIONS ARE REFERENCE AND IN INCHES.
 4. MAX WORKING LOAD: 5,200 LB.

CATALOG NO.	9055
PART NO.	F042274

This drawing contains confidential information that is the property of MacLean Power, L.L.C. ("MacLean"). Use of MacLean's confidential information without MacLean's express written consent is strictly prohibited and may expose you to legal liability. If you believe that you received this material in error, please destroy it or return it to "MacLean Power, L.L.C., 11411 Addison Street, Franklin Park, Illinois 60131, USA."

UNLESS OTHERWISE SPECIFIED DIMENSIONS ARE IN:	
INCHES	
TOLERANCES ARE:	
.X	
.XX	
.XXX	
ANGLES	

MACLEAN POWER SYSTEMS
WWW.MACLEANPOWER.COM

DRAWING NUMBER: GD-9055		DO NOT SCALE DRAWING	
SHEET NAME: Sheet1		1 OF 1	
DRAWING DESCRIPTION: PULLING HOOK		DESIGN DATE: 05-24-88	
DRAWN BY: CAN		ENGINEER: CAN	
APPROVED: MG			
DRAWING SCALE: NONE			