

— GROUNDING DETAIL —

BILL OF MATERIALS			
ITEM NO.	QTY.	DESCRIPTION	MATERIAL
1	1	72" WELDMENT	ALUMINUM
2	1	BONDING CLIP	HOT DIP GALV STEEL
3	1	3/8" X 1-1/4" CARRIAGE BOLT	HOT DIP GALV STEEL
4	1	3/8" LOCKWASHER	HOT DIP GALV STEEL
5	1	3/8" HEX NUT	HOT DIP GALV STEEL

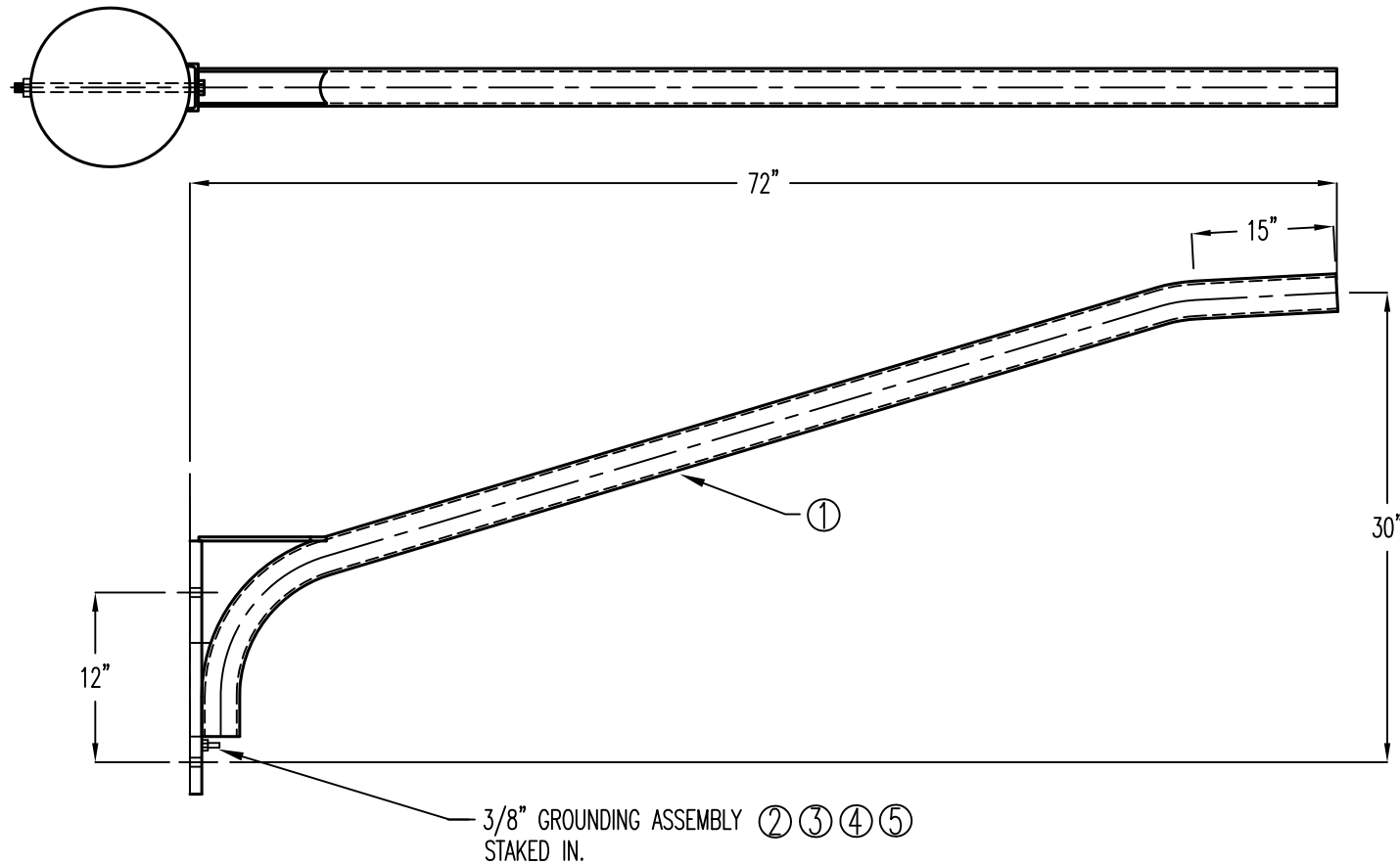

NOTES

- 1.0 MATERIAL:
  - 1.1 SEE TABLE
- 2.0 FINISH:
  - 2.1 HARDWARE: HOT DIP GALVANIZE PER ASTM A-153 SPECIFICATIONS
- 3.0 DIMENSIONS ARE IN INCHES AND REFERENCE.

NO.	DATE	DESCRIPTION	BY
A	4-06-17	NEW RELEASE (ECN D8570)	MB
REVISIONS			

**MacLean Power Systems**  
**Continental Electric**  
 PO Box 835, Trussville, AL 35173  
 Phone: (205)655-7400 Fax: (205)655-3530

DRAWN BY:	APPROVED BY:	SCALE:
MB		NONE
CHECKED BY:		

CATALOG NO. A-2-6TE

LUMINAIRE MOUNTING BRACKET, ALUMINUM

DATE:	DRAWING NO:	SH: 1	R / A
4-06-17	GD-A-2-6TE	OF: 1	

**PROPRIETARY**

This information is confidential and is the property of Maclean Power Systems. It may not be made public or reproduced except that the customer may make copies for use solely in the installation, maintenance, and operation of products supplied by Maclean Power Systems.