

CATALOG NUMBER	CONNECTION TYPE		RUN			TAP			TAP NUT
	RUN	TAP	DIAMETER	MAX	MIN	DIAMETER	MAX	MIN	
C 1520	CU	CU	.128"-.414"	2/0 STR	#8 SOL	.128"-.414"	2/0 STR	#8 SOL	9/16"

PAPER SIZE		DRAWING NUMBER	
C		GD-C1520P	
REV	REVISED BY:	REVISION DATE	ECO #
A	MRM	06-12-12	10638
B	JAM	04-30-15	11778
C	JAA	09-21-15	12004

ITEM NUMBER	1	2	3	4	5	6	7	8
PART DESCRIPTION	TAP BOLT	BODY	EYESCREW	JAW	RIVET	TAPLOCK WASHER	NUT	RUN LOCKWASHER
MATERIAL	BRONZE ALLOY, TIN PLATED	BRONZE ALLOY, TIN PLATED	STAINLESS STEEL	BRONZE ALLOY, TIN PLATED	STAINLESS STEEL	STAINLESS STEEL	STAINLESS STEEL	STAINLESS STEEL

NOTES:
 1) RECOMMENDED TORQUE LEVELS
 RUN: 240 IN-LBS.
 TAP: 240 IN-LBS.

2) STANDARD PACK: 25 PCS

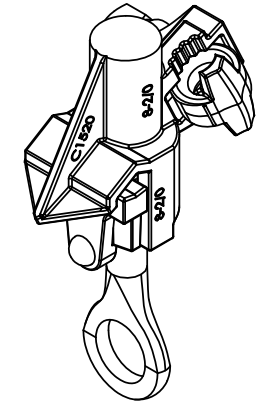
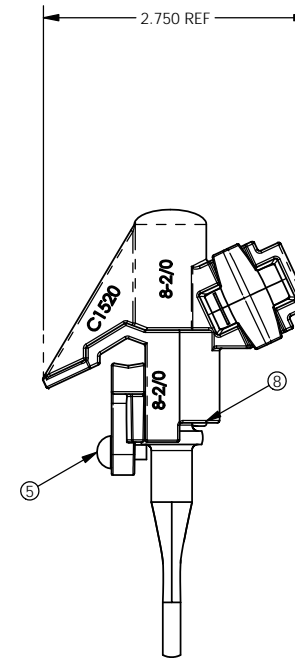
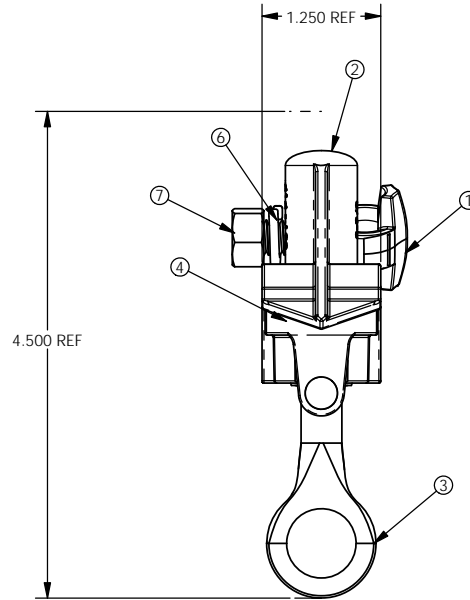

USE OR REPRODUCTION OF THIS DRAWING FOR THE PURPOSE OF MANUFACTURING THIS ARTICLE OR ARTICLES SHOWN OR ANY OTHER PURPOSE IS STRICTLY PROHIBITED EXCEPT ON WRITTEN PERMISSION **MACLEAN POWER SYSTEMS**

UNLESS OTHERWISE SPECIFIED DIMENSIONS ARE IN:	
INCHES	
TOLERANCES ARE:	
.XX	±
.XXX	±
X/XX	±
ANGLES	± °

MACLEAN POWER SYSTEMS
 RELIABLE POWER PRODUCTS
 11411 ADDISON STREET
 FRANKLIN PARK, IL. 60131
 TEL. (847) 455-0014 FAX: (847) 455-0029

DRAWING NUMBER: GD-C1520P		DO NOT SCALE DRAWING	
SHEET NAME: Sheet1		1 OF 1	
DRAWING DESCRIPTION: GENERAL DIMENSION DRAWING C-1520 HOT LINE CLAMP ASSEMBLY		DESIGN DATE: 06-12-12	
DRAWN BY: MRM		ENGINEER: MRM	
APPROVED: JBB		DRAWING SCALE: 1:1	