

CATALOG NUMBER	CONNECTION TYPE		RUN			TAP			TAP NUT
	RUN	TAP	DIAMETER	MAX	MIN	DIAMETER	MAX	MIN	
C 1530	CU	CU	.162"-.745"	400 MCM	#6 SOL	.152"-.682"	4/0 STR	#6 SOL	3/4"

PAPER SIZE		DRAWING NUMBER	
C		GD-C1530	
REV	REVISED BY:	REVISION DATE	ECO #
A	MRM	05-15-12	10617
B	JAA	09-21-15	12004

ITEM NUMBER	1	2	3	4	5	6	7	8
PART DESCRIPTION	TAP BOLT	BODY	EYESCREW	JAW	RIVET	TAP LOCKWASHER	NUT	RUN LOCKWASHER
MATERIAL	BRONZE ALLOY	BRONZE ALLOY	BRONZE ALLOY OR STAINLESS STEEL	BRONZE ALLOY	STAINLESS STEEL	STAINLESS STEEL	BRONZE ALLOY OR STAINLESS STEEL	STAINLESS STEEL

NOTES:

1) RECOMMENDED TORQUE LEVELS  
 RUN: 240 IN-LBS.  
 TAP: 240 IN-LBS.

2) STANDARD PACK: 25 PCS

3) ADD SUFFIX "A" FOR ALUMINUM BODY CLAMPS

4) ADD SUFFIX "-9" FOR PACKAGING WITH INHIBITOR.

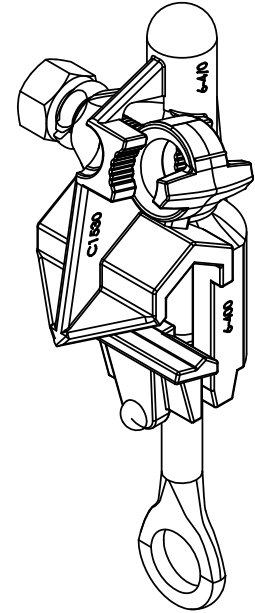
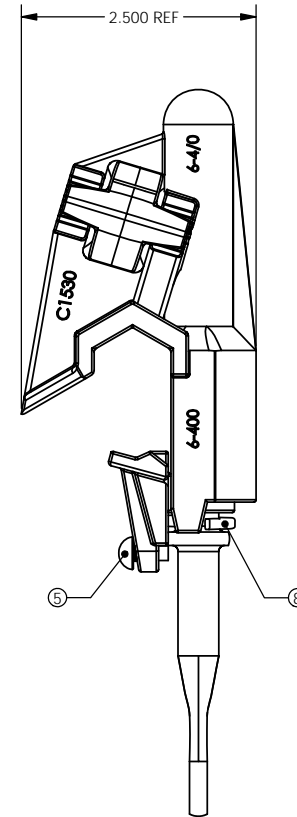
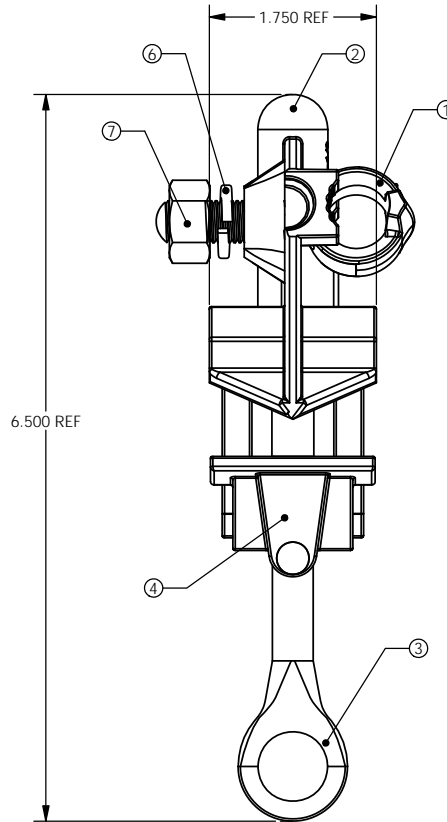

USE OR REPRODUCTION OF THIS DRAWING FOR THE PURPOSE OF MANUFACTURING THIS ARTICLE OR ARTICLES SHOWN OR ANY OTHER PURPOSE IS STRICTLY PROHIBITED EXCEPT ON WRITTEN PERMISSION \*\*MACLEAN POWER SYSTEMS\*\*

UNLESS OTHERWISE SPECIFIED DIMENSIONS ARE IN:	
INCHES	
TOLERANCES ARE:	
XX	±
XXX	±
X/XX	±
ANGLES	± °

**MACLEAN POWER SYSTEMS**  
 RELIABLE POWER PRODUCTS  
 11411 ADDISON STREET  
 FRANKLIN PARK, IL. 60131  
 TEL. (847) 455-0014 FAX: (847) 455-0029

DRAWING NUMBER:		DO NOT SCALE DRAWING	
GD-C1530		CAD GENERATED DRAWING DO NOT MANUALLY UPDATE	
SHEET NAME:	1 OF 1	DESIGN DATE:	05-15-12
DRAWING DESCRIPTION:		DRAWN BY: MRM	
GENERAL DIMENSION DRAWING C1530 HOT LINE CLAMP ASSEMBLY		ENGINEER: MRM	
DRAWING SCALE: 1:2		APPROVED: JBB	