

A | B | C | D | E | F

ITEM	QTY	DESCRIPTION
1	1	ANGLE PIN BODY DETAIL
2	1	.750 X 8.000 SQ HD MACHINE BOLT
3	1	.750 REGULAR SQUARE NUT
4	1	2.250 SQUARE FLAT WASHER
5	1	M-F LOCKNUT 3/4

PAPER SIZE	DRAWING NUMBER	
B SIZE	GD-PA404Z	
REV	REVISION DATE	ECO
A	07-15-11	10304

1

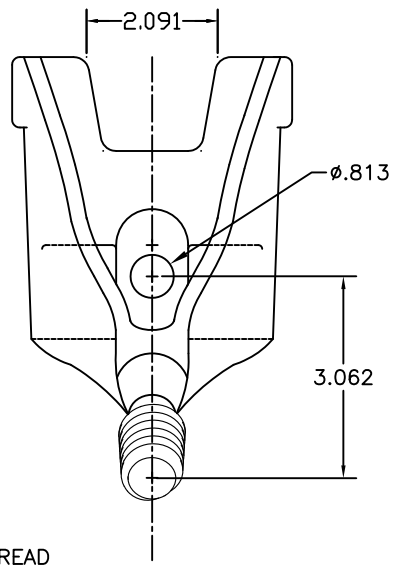
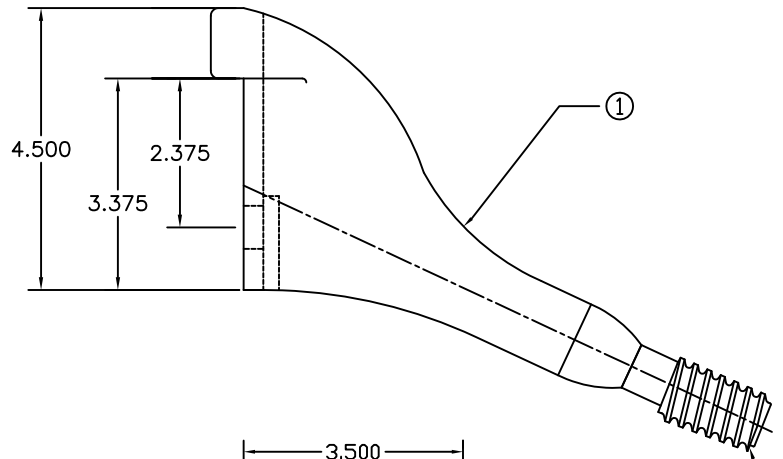

2

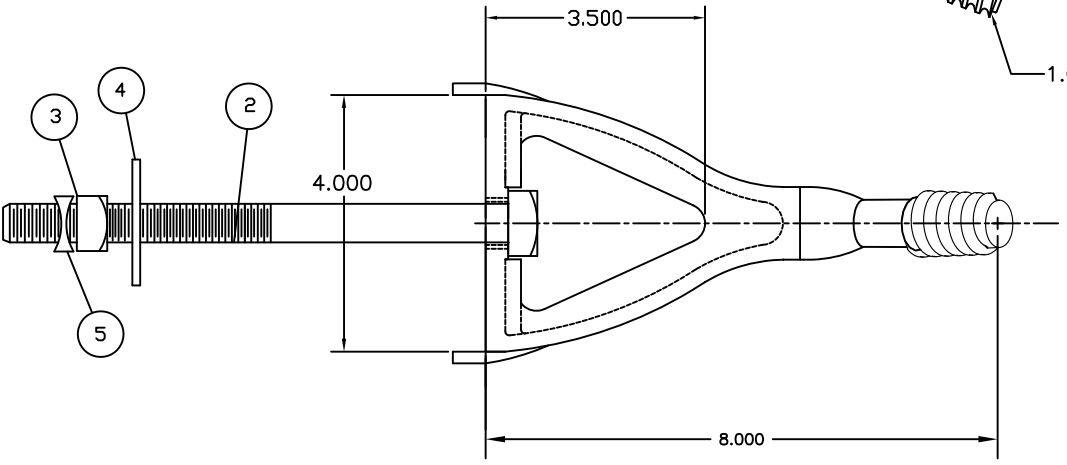

MATERIAL:
 THREAD: NYLON ALLOY
 ITEM 1 (CASTING): DUCTILE IRON
 ITEMS 3-5 (HARDWARE): CARBON STEEL

NOTES:
 1. ALL DIMENSIONS ARE REFERENCE AND IN INCHES.
 2. ALL ITEMS GALVANIZED EXCEPT 1.000 THREAD. WORKMANSHIP PER ASTM A-153.

4

This drawing contains confidential information that is the property of MacLean Power, L.L.C. ("MacLean"). Use of MacLean's confidential information without MacLean's express written consent is strictly prohibited and may expose you to legal liability. If you believe that you received this material in error, please destroy it or return it to "MacLean Power, L.L.C., 11411 Addison, Franklin Park, Illinois 60131, USA."

DRAWING-COMPUTER LOCATION

TOLERANCES UNLESS SPECIFIED	inch
0.XX	— — —
0.XXX	— — —
ANGLE	— — —



DRAWN BY	ENGINEER	CHECKER	CATALOG #	SCALE	DESIGN DATE
RRL	RRL	JBB	PA404Z	NTS	7-7-11
DRAWING TITLE / DESCRIPTION					DRAWING NUMBER
PIN ANGLE N/A THREAD					GD-PA404Z