

PAPER SIZE		DRAWING NUMBER	
B		GD-TG-820	
REVISIONS			
REV.	REVISED BY:	DATE	ECR
A	ACJ	12-02-2024	11608
B	CLF	5-23-2024	D9044

CATALOG NUMBER	CABLE RANGE		STUD THREAD SIZE UNC-2A
	MINIMUM	MAXIMUM	
TG-820	#8 SOL	2/0 STR	1/2"-13

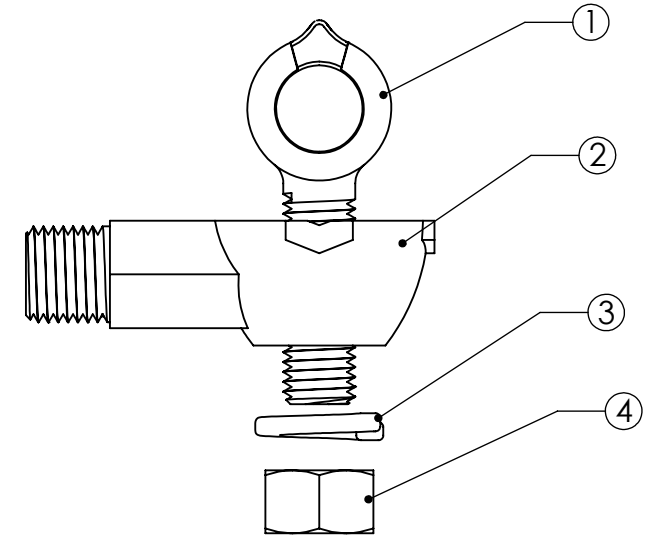
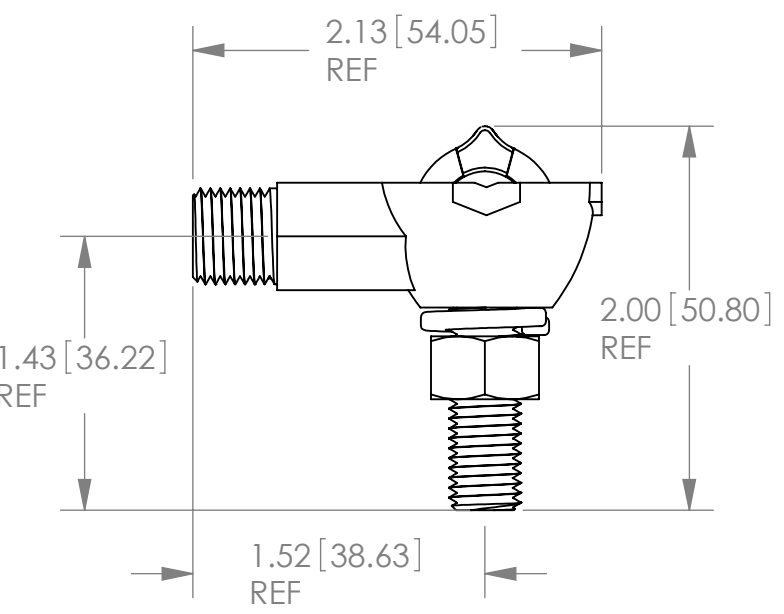
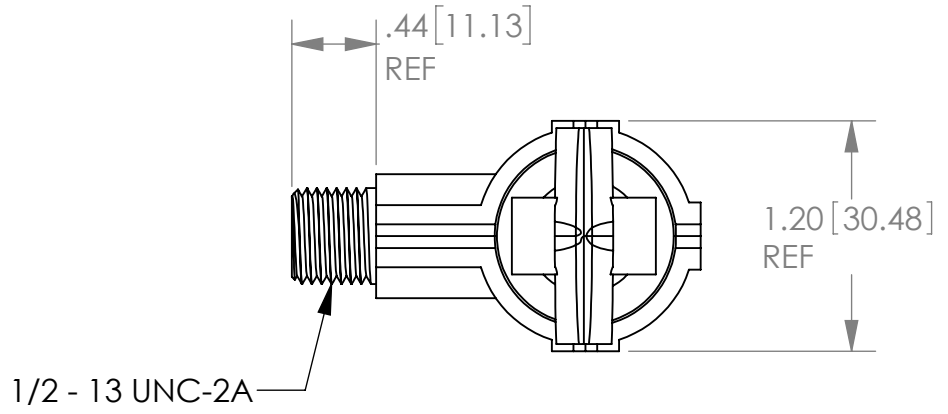
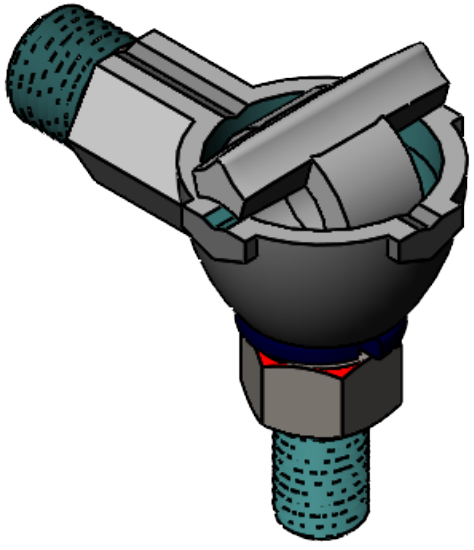

NOTES:

1. ALL DIMENSIONS ARE REFERENCE AND ARE IN INCHES [CM].
2. CONNECTOR MINIMUM TORQUE STRENGTH OF 120 IN-LBS [13.6 N.m].

ITEM #	DESCRIPTION	QTY	MATERIAL
1	TG-820 "T-BOLT"	1	BRONZE
2	TG-820 "BODY"	1	BRONZE
3	3/8 LOCK WASHER	1	STAINLESS STEEL
4	3/8-16 HEX NUT	1	STAINLESS STEEL

This drawing contains confidential information that is the property of MacLean Power, L.L.C. ("MacLean"). Use of MacLean's confidential information without MacLean's express written consent is strictly prohibited and may expose you to legal liability. If you believe that you received this material in error, please destroy it or return it to "MacLean Power, L.L.C., 11411 Addison Street, Franklin Park, Illinois 60131, USA."

WWW.MACLEANPOWER.COM

DRAWING NUMBER: GD-TG-820		DO NOT SCALE DRAWING	
SHEET NAME: F-041795		CAD GENERATED DRAWING DO NOT MANUALLY UPDATE	
DRAWING DESCRIPTION: TG-820		DESIGN DATE: 5/23/2024	
DRAWING SCALE: 1:1		DRAWN BY: CLF	
		ENGINEER: CLF	
		APPROVED: MEG	
		REVISION: A	