



MacLean Power Systems  
7801 Park Place Rd., York, SC 29745  
USA (803) 628-2100

MPS Catalog Number

**H7 90 20 016 MX SS 008**

Revision: PD-2

Date 4/4/2023

**End Fittings**

Tower End Fitting:

1 Piece Gain Base (Aluminum)

Line End Fitting:

Trunnion

**Material**

Number of Sheds:

8

Rod Diameter:

1-3/4"

Weight Estimate:

16.5 lbs

7.5 kg

**Dimensional Values**

Section Length (L):

25.7 in 617 mm

Rubber Length (X):

15.9 in 404 mm

Shed Height (P):

2.4 in 62 mm

Shed Diameter (B):

6.9 in 175 mm

Shed Spacing (S):

2.0 in 52 mm

Dry Arc Distance:

18.4 in 467 mm

Leakage Distance:

51.5 in 1308 mm

**Electricals Values**

60 Hz dry Flashover:

211 kV

Min. Withstand

177 kV

60 Hz Wet Flashover:

169 kV

Min. Withstand

128 kV

Positive CIFO:

320 kV

Min. Withstand

283 kV

Negative CIFO:

372 kV

Min. Withstand

316 kV

**Mechanical Values**

Max. Design Cant. Load (MDCL):

1,350 lbs 6.0 kN

Specified Cant. Load (SCL):

2,800 lbs 12.5 kN

Specified Tensile Load (STL):

5,000 lbs 22.2 kN

This drawing contains confidential information that is the property of MacLean Power, L.L.C. ("MacLean"). Use of MacLean's confidential information without MacLean's express written consent is strictly prohibited and may expose you to legal liability. If you believe that you received this material in error, please destroy it or return it to "MacLean Power, L.L.C., 7801 Park Place Rd., York, South Carolina 29745, USA."

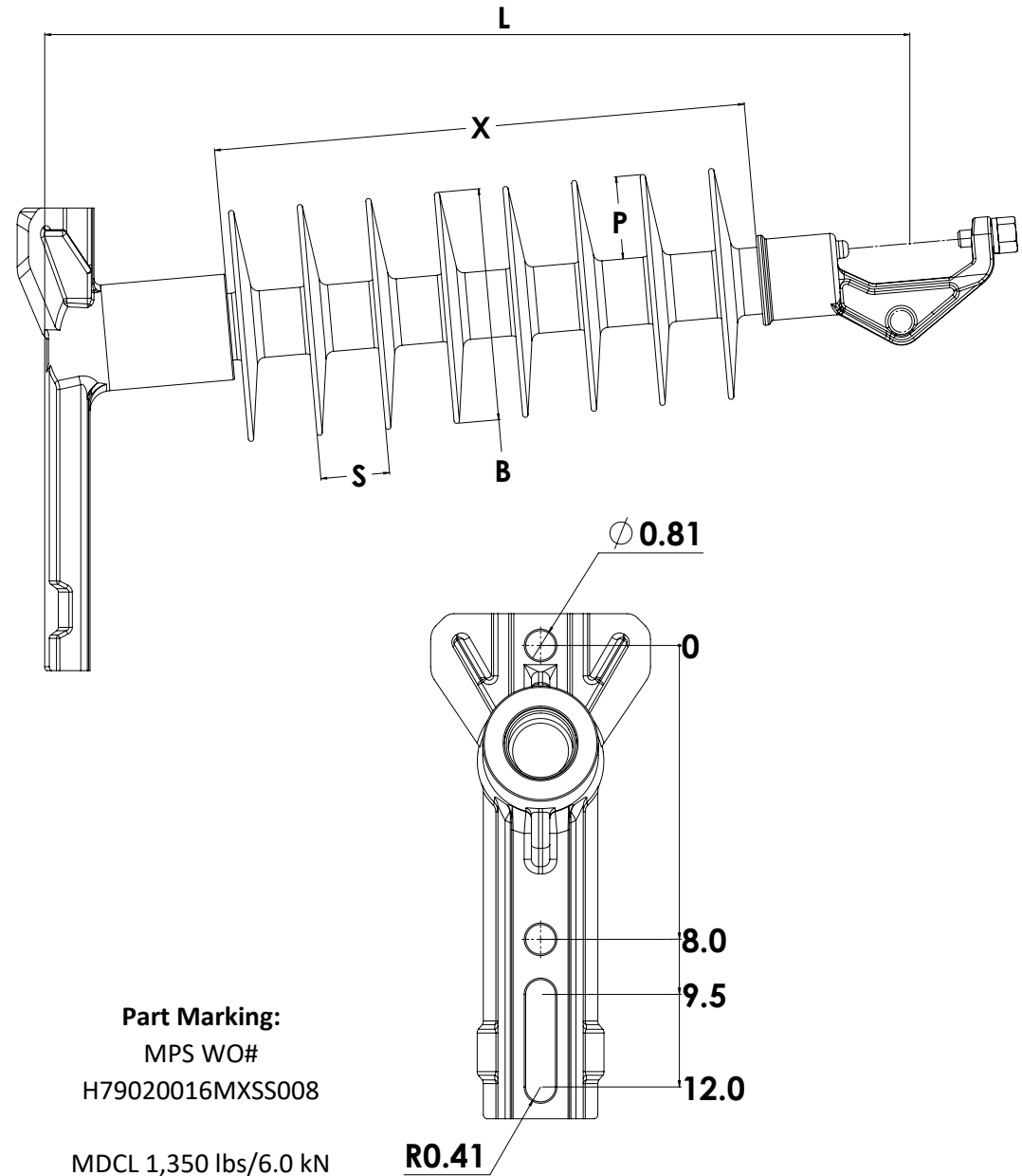

**Part Marking:**

MPS WO#  
H79020016MXSS008

MDCL 1,350 lbs/6.0 kN

Dimension: inches [millimeters]

NOTE: Drawing not actual depiction of insulator appearance

**R0.41**

Insulator assembly complies with ANSI C.29.18 and CSA C411.6 Standards