

MPS Catalog Number:

MG528Z

Rev:		E
Date:		3/30/2026
ANSI Class:		ANSI 52-8H
Ball and Socket Coupling:	w/ Zinc Sleeve	Type K
Shell Profile:		Standard
Weight:	13.2 lbs	6.0 kg

DIMENSIONS

Diameter (D):	11.0 in	280 mm
Spacing:	5.75 in	146 mm
Leakage Distance:	15.7 in	400 mm

ELECTRICAL VALUES

Low Frequency Dry Flashover:	80 kV
Low Frequency Wet Flashover:	50 kV
Critical Impulse Flashover Positive (CIFO +):	125 kV
Critical Impulse Flashover Negative (CIFO -):	130 kV
Low Frequency Puncture Voltage:	130 kV
Radio Influence Voltage(RIV) Test Voltage:	10 kV
Maximum RIV at 1 MHz:	50 µV

MECHANICAL VALUES

Combined Electrical & Mechanical (M&E) Rating	40 klb	178 kN
Routine Test Mech. Proof Load:	20 klb	89 kN
Impact Strength:	400 in-lbs	45 N-m

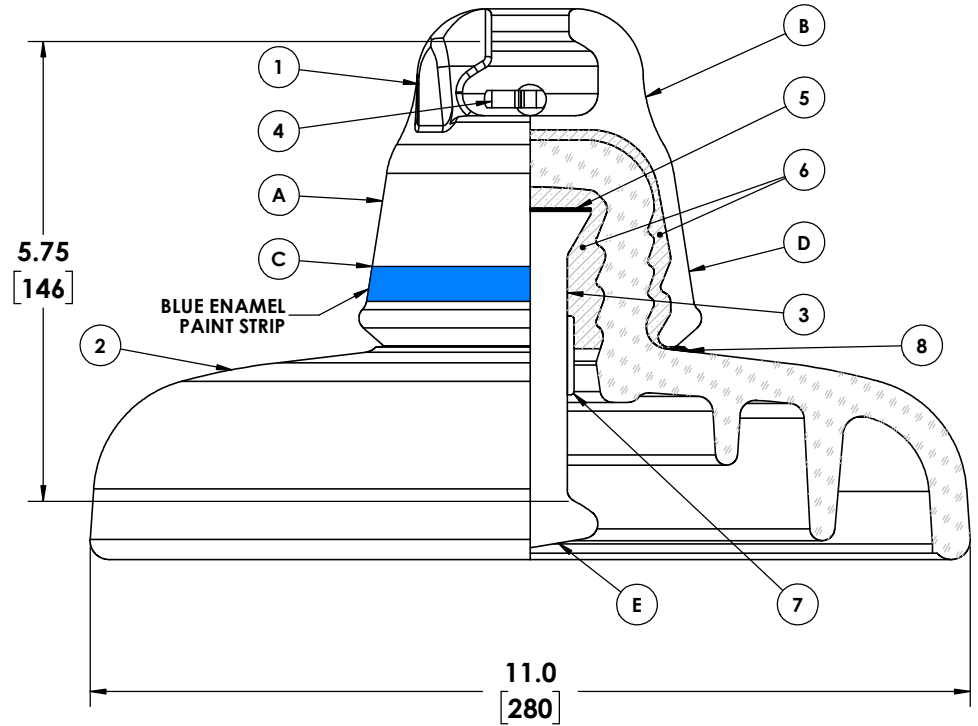

A INSULATOR SUPPLIER MARKING	B CAP SUPPLIER MARKING	C TEST 20000 M&E 40000 MG528Z	D YEAR OF MANUFACTURE YYYY	E COUNTRY OF ORIGIN STAMP
-------------------------------------	-------------------------------	--------------------------------------	-----------------------------------	----------------------------------

Item#	Qty	Description	Material
1	1	Cap	Hot Dip Galvanized Cast Iron
2	1	Shell	Toughened Glass
3	1	Pin	Hot Dip Galvanized Forged Steel
4	1	Cotter Pin	Stainless Steel ANSI
5	1	Gasket	Asphalt Felt
6	---	Cement	Aluminous Cement, Hot Cured
7	1	Zinc Sleeve	Zinc
8	1	Coating	Pile