

|            |      |                    |        |
|------------|------|--------------------|--------|
| PAPER SIZE |      | DRAWING NUMBER     |        |
| <b>B</b>   |      | <b>X3RA1YB30A2</b> |        |
| REV        | DATE | DESCRIPTION        | REV BY |
|            |      |                    |        |
|            |      |                    |        |
|            |      |                    |        |

| ITEM NO. | PART NUMBER | DESCRIPTION             | QTY. | MATERIAL     | ULTIMATE STRENGTH |
|----------|-------------|-------------------------|------|--------------|-------------------|
| 1        | ASH-66-BC   | ANCHOR SHACKLE          | 1    | FORGED STEEL | 60,000 LBS.       |
| 2        | SYCR-56     | SOCKET Y-CLEVIS         | 1    | DUCTILE IRON | 30,000 LBS.       |
| 3        | ASM-641-2   | TURN YOKE               | 1    | DUCTILE IRON | 50,000 LBS.       |
| 4        | -           | CORONA FREE SUSP. CLAMP | -    | ALUMINUM     | 25,000 LBS.       |
| 5        | -           | Y-CLEVIS INSULATOR      | -    | COMPOSITE    | -                 |

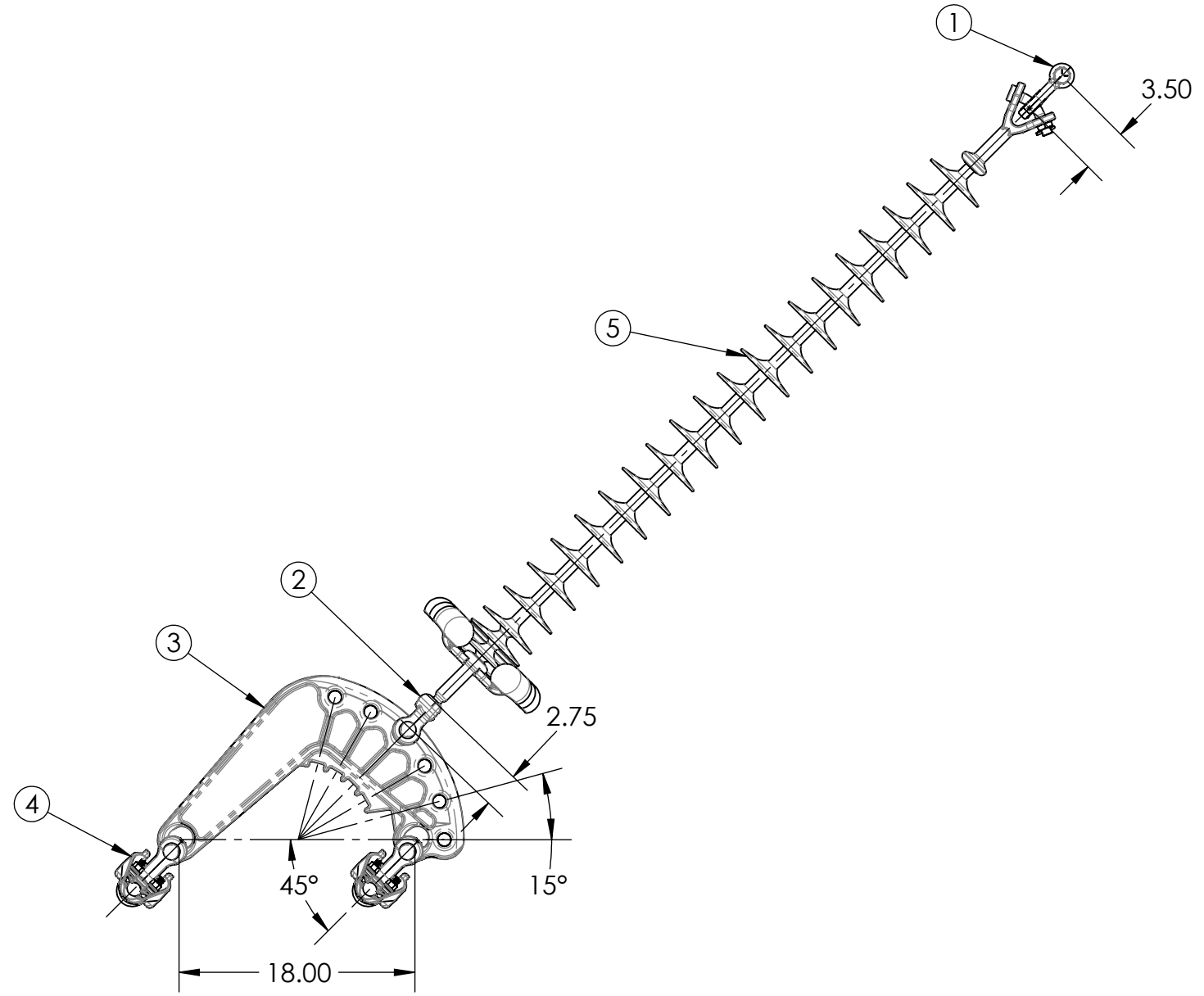

NOTE: INSULATORS AND CONDUCTOR KIT SOLD SEPARATELY

ASSEMBLY CAT. NO. X3RA1YB30A2

This drawing contains confidential information that is the property of MacLean Power, L.L.C. ("MacLean"). Use of MacLean's confidential information without MacLean's express written consent is strictly prohibited and may expose you to legal liability. If you believe that you received this material in error, please destroy it or return it to "MacLean Power, L.L.C., 11411 Addison Street, Franklin Park, Illinois 60131, USA."

UNLESS OTHERWISE SPECIFIED DIMENSIONS ARE IN:

**INCHES**

| TOLERANCES ARE: |           |
|-----------------|-----------|
| .X              | +/- 0.1   |
| .XX             | +/- 0.03  |
| .XXX            | +/- 0.015 |
| ANGLES          | +/- 1.0   |



|   |   |
|---|---|
| DRAWING NUMBER:<br><b>X3RA1YB30A2</b>                 | DO NOT SCALE DRAWING                            |
| SHEET NAME:<br><b>SHEET1</b>                          | CAD GENERATED DRAWING<br>DO NOT MANUALLY UPDATE |
| 1 OF 1  | DESIGN DATE: 3/25/24                            |
| DRAWING DESCRIPTION:<br><b>RUNNING ANGLE ASSEMBLY</b> | DRAWN BY: JIP                                   |
|   | ENGINEER:                                       |
|   | APPROVED:                                       |
| DRAWING SCALE: 1:1                                    |   |